



G. C. E. (Advanced Level)

PHYSICS
Practical Handbook

(effective from year 2017)

Department of Science
Faculty of Science and Technology
National Institute of Education

www.nie.lk

G. C. E. (Advanced Level)
Physics
Practical Handbook

© National Institute of Education

ISBN: -

Department of Science
National Institute of Education

Website : www.nie.lk

Message from the Director General

With the intention of realising the National Educational Objectives recommended by the National Education Commission and with the primary intention of developing common competencies, the content based curriculum which was earlier effective was modernised and the first phase of the new competency based curriculum of an eight year cycle was introduced by the National Institute of Education to the primary and the secondary education system of Sri Lanka in 2007.

Based on the facts revealed by research and the suggestions by various sectors on education, a curriculum rationalization process has resulted in the second phase of the curriculum cycle which has commenced its introduction from 2015.

The primary intention of the new rationalized curriculum is to admit the student community into a more student centered and activity based education pattern while transforming to a human resource armed with skills and competencies required for the world of work.

In this rationalization process, to orderly build up all subject competencies from base level to the higher level the vertical integration method has been employed, while to minimise as much as possible the repetition of the same subject matter over and over again and to limit the subject content and develop a student friendly curriculum which can be implemented, the horizontal integration method has been employed.

In teaching - learning process of science, practical work is an important component. The engagement in practical work at a high level enables the students to develop their talents, to understand the scientific investigation process and enhance their conceptual knowledge.

This practical handbook is prepared with the intention of guiding both the teacher - student sectors to successfully perform activities of planning practical experiments, efficient engagement of students in the learning process and uplifting their practical talents in the field of Physics.

I take this opportunity to convey my gratitude to the members of the Council and of the Academic Affairs Board of the NIE and the resource persons who contributed to the preparation of this practical handbook for their dedication to achieve success in this matter.

Dr. (Mrs) T. A. R. J. Gunasekara

Director General

National Institute of Education

Maharagama

Message from the Director (Science)

This practical handbook has been compiled to assist the student in reaching expertise in the subject area of science. We have been in consultation with university lecturers, teachers and curriculum experts during the designing of this book. The experiments in this handbook are introduced with the intention of achieving the objectives of the physics curriculum. Stated below are three reasons which may be interrelated regarding the importance of performing practical experiments in school, but can be mentioned as separate ones.

1. Assistance to build up scientific concepts (knowledge and comprehension) and integration of theoretical matters with practical matters
2. Developing investigational talents
3. Building up practical talents and to excel in it

During performing and experimenting we believe that the teacher being concerned of the above mentioned reasons would assist the student to have a better understanding of the subject, to uplift in him/ her the talents possessed by a scientist, to have manipulative skills required for further education and job opportunities connected with STEM subjects (Science, Technology, Engineering and Mathematics). In order to make practical work effective, the laboratory should be made a place of learning by doing. Also, the teacher should provide guidance to maintain the following norms inside the laboratory.

- Keeping the place of work clean
- High concern by students about their activities
- Keeping the tables of the laboratory free of stoppers of chemical bottles
- Minimising wastage of water, gas and electricity
- Reading carefully and following the guidance provided for the respective experiment
- Teachers should allow the student's entry in lab in his/ her presence
- Performing only those experiments allocated by the teacher

I take this opportunity to express my gratitude to all university lecturers, teachers and other resource persons who contributed in their endeavour to the successful production of the practical handbook. Also finally I wish that this attempt will be helpful to strengthen our young generation as members of societies rich in information and technologically advanced.

Dr. A. D. Asoka de Silva

Director

Department of Science

National Institute of Education

Resource Contribution (2018 revised copy)

Guidance	Dr. (Mrs) T. A. R. J. Gunasekara, Director General, National Institute of Education
Supervision	Dr. A. D. Asoka de Silva, Director, Department of Science, National Institute of Education
Subject leadership	P. Malavipathirana, Senior Lecturer, Department of Science, National Institute of Education
Editing	P. Malavipathirana, Senior Lecturer, National Institute of Education Dr. M. L. S. Piyatissa, Assistant Lecturer, Department of Science, National Institute of Education Miss R. A. Amarasinghe, Assistant Lecturer, Department of Science, National Institute of Education
English translation	D. S. Withanachchi, Former Chief Project Officer (Education Technology), National Institute of Education
English language editing	Dr. (Mrs.) Chandra Amarasekara Consultant, National Institute of Education
Typesetting and page designing	Jayaruwan Vijayawardhana, Freelance Computer Graphic Designer
Laboratory assistance	M. Welipitiya, Laboratory Assistant, Department of Science, National Institute of Education
Other assistance	(Mrs) W. P. P. Weerawardhana, Department of Science, National Institute of Education K. R. Dayawansa, Department of Science, National Institute of Education

Resource Contribution (2015 First Copy)

Instructions	Prof. W. M. Abeyrathna Bandara Director General, National Institute of Education
Guidance and direction	M. F. S. P. Jayawardena, Deputy Director General, Faculty of Science and Technology, National Institute of Education
Subject coordination	M. L. S. Piyatissa, Assistant Lecturer, Department of Science, National Institute of Education
Editing	P. Malavipathirana, Senior Lecturer, Department of Science, National Institute of Education M. L. S. Piyatissa, Assistant Lecturer, Department of Science, National Institute of Education Mrs. M. R. P. I. J. Herath, Assistant Lecturer, Department of Science, National Institute of Education W. D. I. Upamal, Assistant Lecturer, Department of Science, National Institute of Education Miss R. A. Amarasinghe, Assistant Lecturer, Department of Science, National Institute of Education
Panel of writers	P. Malavipathirana, Senior Lecturer, Department of Science, National Institute of Education W. A. D. Rathnasuriya, Former Chief Project Officer (Physics), National Institute of Education B. A. Tilakaratne, Former Project Officer (Physics), National Institute of Education D. S. Vithanachchi, Former Chief Project Officer (Education Technology), National Institute of Education H. S. K. Wijethilake, Former SLEAS - I A. Sugathapala, Former Teacher Service - I A. Hettiarachchi, Senior Program Officer, National Education Commission
Subject guidance and evaluation	Emeritus Professor of Physics, T. R. Ariyaratne Prof. S. R. D. Rosa, University of Colombo Prof. J. K. D. S. Jayanetti, University of Colombo

Dr. M. K. Jayananda, University of Colombo
Prof. K. P. S. C. Jayarathne, University of Colombo
Prof. D. D. N. B. Daya, University of Colombo
Dr. I. K. Perera, Former Senior Professor
Dr. G. M. L. P. Aponsu,
Sabaragamuwa University of Sri Lanka
Dr. B. S. B. Karunaratne, Former Senior Professor
Dr. P. W. S. K. Bandaranayake, University of Peradeniya
Dr. L. R. A. K. Bandara, University of Peradeniya
Dr. (Mrs.) V. A. Seneviratne, University of Peradeniya
Dr. J. P. Liyanage, University of Peradeniya
Dr. C. P. Jayalath, University of Peradeniya
Prof. J. C. N. Rajendra, Open University of Sri Lanka
Prof. W. G. D. Dharmarathne, University of Ruhuna
Dr. J. A. P. Bodhika, University of Ruhuna
Prof. S. R. D. Kalingamudali, University of Kelaniya
Dr. P. Geekiyanage, University of Sri Jayewardenepura

**Independent
evaluation**

P. Wickramasekara, Teacher Service - I,
Buddhist Girls' College, Mount Lavinia
J. R. Lankapura, Teacher Service - I,
Wickramashila Central College, Giriulla

Diagrams

W. A. D. Rathnasuriya
Former Chief Project Officer (Physics)
National Institute of Education
J. R. Lankapura, Teacher Service - I,
Wickramashila Central Collage, Giriulla
Jayaruwan Vijayawardhana,
Freelance Computer Graphic Designer

Laboratory assistance

M. Welipitiya, Lab Assistant,
Department of Science, National Institute of Education

Other assistance

Mrs. W. P. P. Weerawardena,
Department of Science, National Institute of Education
K. R. Dayawansa,
Department of Science, National Institute of Education

Introduction

The Physics practical handbook has been prepared by the Science Department of the National Institute of Education for the use of both teachers and students by including detailed instructions on 42 laboratory experiments related to the Physics (Advanced Level) syllabus effective from the year 2017. The list of practical experiments on the 2017 syllabus is included in the pages x and xi of the handbook. Although the practical handbook serves both teachers and students, it is advisable that student will always engage in practicals with the teacher knowledge and guidance. Both teacher-student sectors should take care to adhere to the ethics and the safety measures as relevant inside the laboratory.

In this book, for each experiment, after the name of the experiment are lists. Necessary information is provided with materials and apparatus, theory, method, readings and calculations, conclusions and relevant illustrations. Special details to be mentioned are given under the caption 'note'. The record of the experiment should be prepared by the student under proper guidance. In addition to the experiments given here in, in order to strengthen the learning-teaching process, the teacher has the freedom to plan more relevant practical activities, teacher demonstrations and practical experiments etc.. Instructions are given to restrict the usage of mercury as much as possible. The first copy of this book was prepared and completed in the year 2015 as a book of instructions for 46 laboratory experiments pertaining to the syllabus that was effective from the year 2009 (and revised in the year 2012). Almost all the experiments here had been tested when preparing that book. When the book was edited to suit the new syllabus which came into effect from 2017, the following main amendments were effected.

- Removal of following experiments from the 2009 practical list.

Experiment No.	Name of experiment
32	Comparison of two resistances using the metre bridge
35	Comparison of resistances using the potentiometer
37	Determination of very small e.m.f.s (that of a thermocouple) using the potentiometer
44	Determination of the surface tension of a soap film using a wire frame

- In experiment no. 24: 'To verify the relationship between the pressure of a gas and its absolute temperature at constant volume', explanation of the usage of the 'Borden pressure gauge' instead of the 'constant volume gas apparatus' was instituted.

In addition, a special matter that should be brought to the notice of the teachers is that they have many opportunities for research activities on Physics education in field such as planning practical experiments, improving and evaluating them.

Furthermore, if the Department of Science is made aware of any defects and omissions etc of the experiments in this book it will be of great help in future revisions.

**Practical list for the G. C. E. (Advanced Level)
Physics Syllabus effective from the year 2017**

1. Usage of the vernier callipers
2. Usage of the micrometer screwgauge
3. Usage of the spherometer
4. Usage of the travelling microscope
5. Verification of the law of parallelogram of forces and using it to determine the mass of a body
6. Determination of the mass of a body using the principle of moments
7. Determination of the relative density of a liquid using the U tube
8. Determination of the relative density of a liquid using Hare's apparatus
9. Determination of the density of a liquid using a weighted test tube
10. Determination of the acceleration due to gravity using the simple pendulum
11. Verification of the relationship between the mass of a body suspended from a helix spring and its period of oscillation
12. Determination of the frequency of a tuning fork using the sonometer
13. Verification of the relationship between the frequency of a stretched string and its vibrating length using the sonometer
14. Determination of the velocity of sound using a closed resonance tube and a tuning fork and also determination of the end correction of the tube
15. Determination of the velocity of sound in air using a closed resonance tube and a set of tuning forks and also determination of the end correction of the tube
16. Determination of the refractive index of glass using the travelling microscope and a block of glass
17. Determination of the angle of minimum deviation of a prism by observing the variation of deviation in a ray caused by the prism
18. Determination of the refractive index of the material of a prism by the critical angle method
19. Adjustment of a spectrometer and using it for determination of the refracting angle of a prism
20. Determination of the angle of minimum deviation of a prism and the refractive index of the material of the prism using the spectrometer
- 21.1. Location of the images formed by a convex lens by the method of no-parallax and hence determination of the focal length of the lens
- 21.2. Location of the images formed by concave lens by the method of no-parallax and hence determination of the focal length of the lens

22. Determination of the atmospheric pressure using the quill tube
23. Verification of the relationship between the volume and the temperature of a gas at constant pressure
24. To verify the relationship between the pressure and the absolute temperature of a gas at constant level
25. Determination of the specific heat capacity of a solid substance by the method of mixtures
26. Determination of the specific heat capacity of a liquid by the method of cooling
27. Determination of specific latent heat of fusion of ice by the method of mixtures
28. Determination of the specific latent heat of vaporization of water by the method of mixtures
29. Determination of relative humidity of air using a polished calorimeter
30. Determination of the thermal conductivity of a metal by Searle's method
31. Determination of the internal resistance and the electromotive force of a dry cell
32. Determination of temperature coefficient of resistance of a metal (Cu) using the Metre Bridge
33. Comparison of electromotive forces of two cells using the potentiometer
34. Determination of the internal resistance of a cell using the potentiometer
35. Construction of the I - V curve for a forward biased semiconductor diode
36. Construction of the transfer characteristic curve between I_B and I_C of a transistor in common emitter configuration
37. Experimental investigation of the truth tables of simple fundamental logic gates and hence identification of the given gates
38. Determination of the Young's modulus of a metal (steel) in the form of a wire
39. Determination of the coefficient of viscosity of a liquid (water) by capillary flow method using Poiseuill's formula
40. Determination of the surface tension of water using a microscope slide
41. Determination of the surface tension of water by capillary rise method
42. Determination of the surface tension of a liquid by Jaeger's method

Contents

	Pages
Message from the Director General	iii
Message from the Director (Science)	iv
Introduction	viii
Practical List	x
1. Usage of the vernier callipers	1
2. Usage of the micrometer screwgauge	6
3. Usage of the spherometer	9
4. Usage of the travelling microscope	11
5. Verification of the law of parallelogram of forces and using it to determine the mass of a body	14
6. Determination of the mass of a body using the principle of moments	16
7. Determination of the relative density of a liquid using the U tube	18
8. Determination of the relative density of a liquid using Hare's apparatus	20
9. Determination of the density of a liquid using a weighted test tube	22
10. Determination of the acceleration due to gravity using the simple pendulum	24
11. Verification of the relationship between the mass of a body suspended from a helix spring and its period of oscillation	26
12. Determination of the frequency of a tuning fork using the sonometer	28
13. Verification of the relationship between the frequency of a stretched string and its vibrating length using the sonometer	30
14. Determination of the velocity of sound using a closed resonance tube and a tuning fork and also determination of the end correction of the tube	32
15. Determination of the velocity of sound in air using a closed resonance tube and a set of tuning forks and determination of the end correction of the tube	34
16. Determination of the refractive index of glass using the travelling microscope and a block of glass	36
17. Determination of the angle of minimum deviation of a prism by observing the variation of deviation of a ray caused by the prism	38
18. Determination of the refractive index of the material of a prism by the critical angle method	40
19. Adjustment of a spectrometer and using it for determination of the refracting angle of a prism	42
20. Determination of the angle of minimum deviation of a prism and the refractive index of the material of the prism using the spectrometer	45

21.1.	Location of the images formed by a convex lens by the method of no-parallax and hence determination of the focal length of the lens	47
21.2.	Location of the images formed by concave lens by the method of no-parallax and hence determination of the focal length of the lens	51
22.	Determination of the atmospheric pressure using the quill tube	53
23.	Verification of the relationship between the volume and the temperature of a gas at constant pressure	55
24.	To verify the relationship between the pressure and the absolute temperature of a gas at constant level	57
25.	Determination of the specific heat capacity of a solid substance by the method of mixtures	59
26.	Determination of the specific heat capacity of a liquid by the method of cooling	61
27.	Determination of specific latent heat of fusion of ice by the method of mixtures	64
28.	Determination of the specific latent heat of vaporization of water by the method of mixtures	66
29.	Determination of relative humidity of air using a polished calorimeter	68
30.	Determination of the thermal conductivity of a metal by Searle's method	70
31.	Determination of the internal resistance and the electromotive force of a dry cell	73
32.	Determination of temperature coefficient of resistance of a metal (Cu) using the Metre Bridge	75
33.	Comparison of electromotive forces of two cells using the potentiometer	77
34.	Determination of the internal resistance of a cell using the potentiometer	79
35.	Construction of the I - V curve for a forward biased semiconductor diode	81
36.	Construction of the transfer characteristic curve between I_B and I_C of a transistor in common emitter configuration	83
37.	Experimental investigation of the truth tables of simple fundamental logic gates and hence identification of the given gates	85
38.	Determination of Young's modulus of a metal (steel) in the form of a wire	87
39.	Determination of the coefficient of viscosity of a liquid (water) by capillary flow method using Poiseuill's formula	90
40.	Determination of the surface tension of water using a microscope slide	92
41.	Determination of the surface tension of water by the capillary rise method	94
42.	Determination of the surface tension of a liquid by Jaeger's method	96
	References	99

Usage of the vernier callipers

1. Finding the volume of a block of wood
2. Finding the volume of the material of a PVC tubing
3. Finding the volume of the material of a solid sphere
4. Finding the internal volume of a hollow cylinder

Materials and apparatus

A vernier calliper, a block of wood (of about 2 cm × 4 cm × 6 cm), a PVC tubing (1.3 cm (½"), 6 cm), a solid sphere (of diameter about 2 cm) and a hollow cylinder (Archimedes cylinder and bucket)

Theory

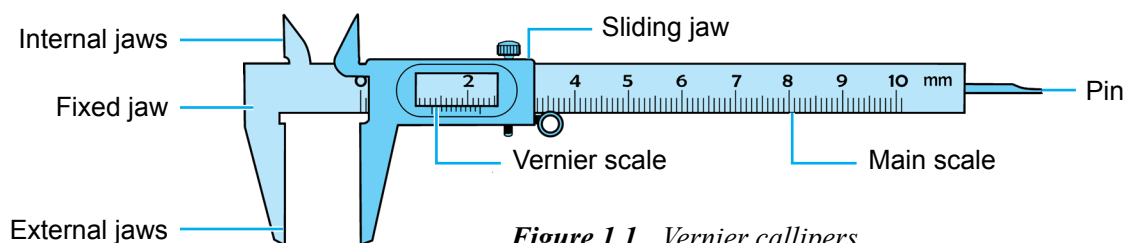

Figure 1.1 Vernier callipers

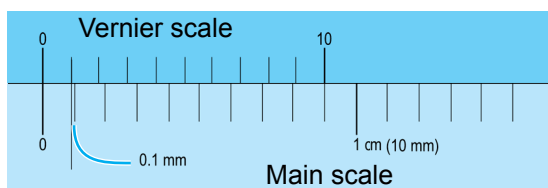

Figure 1.2 Magnified view of the vernier scale and the main scale

$$\text{Least count} = 1 - \frac{9}{10} = \left(\frac{1}{10} \right)$$

If the vernier calliper of the school laboratory has n divisions of its main scale divided into N divisions of the vernier scale,

$$\text{Least count in relevant units} = \left(1 - \frac{n}{N} \right) \times \text{length of a smallest division of the main scale}$$

1. If the length is l , breadth is b and height is h of the wooden block, its volume = $l b h$

2. If the external diameter is d_0 , the internal diameter is d_i and length is l of the tube,

$$\text{Volume of the material of the tube} = \left[\pi \left(\frac{d_0}{2} \right)^2 - \pi \left(\frac{d_i}{2} \right)^2 \right] l$$

3. If the diameter of the sphere is d , its volume = $\frac{4}{3} \pi \left(\frac{d}{2} \right)^3$

4. If the depth of the hollow cylinder is l and its internal diameter d ,

$$\text{the volume of the cavity of the tube} = \pi \left(\frac{d}{2} \right)^2 l$$

Method

Find and note down the least count of the given vernier calliper.

1. Measurement of length, breadth and height of the wooden block

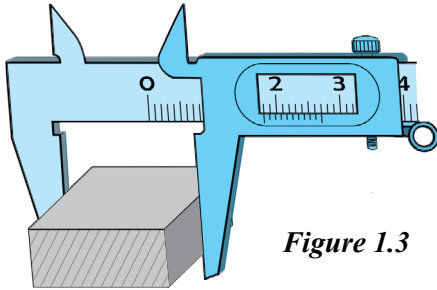

Figure 1.3

- When taking measurements of the block hold it between the jaws of the caliper and calculate readings.
- Take measurements at three places for length, breadth and height and note down readings in Table 1.1.

2. Finding the volume of the material of the PVC tubing

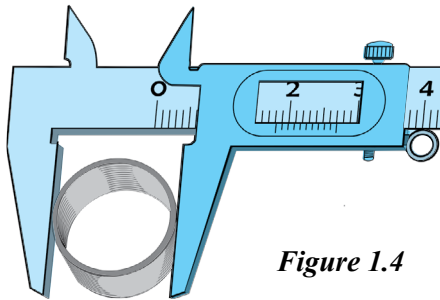

Figure 1.4

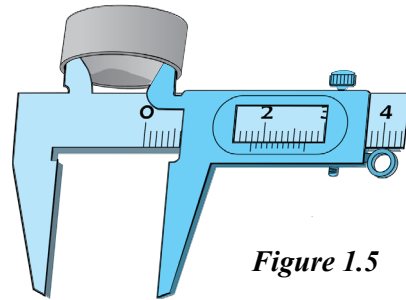

Figure 1.5

- When measuring the external diameter of the PVC tubing adjust the vernier caliper as shown in Figure 1.4 and calculate readings.
- Take measurements of two diameters normal to each other and record in Table 1.2
- When measuring the internal diameter of the tubing adjust the vernier caliper as shown in Figure 1.5 and obtain readings.
- Take measurements of two diameters normal to each other and record in Table 1.2
- Measure the length of the tubing in three positions and record in Table 1.2 (Take care to select these three positions keeping equal gaps between them.)

3. Finding the volume of the material of a solid sphere

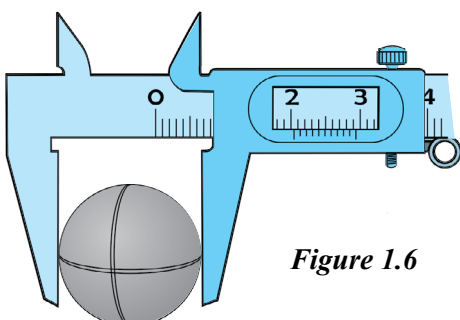

Figure 1.6

- When measuring the diameter of the sphere adjust the vernier caliper as shown in Figure 1.6 and calculate the readings.
- Take measurements of two diameters normal to each other and note down in Table 1.4

4. Finding the internal volume of a hollow cylinder

- Calculate the internal diameter of the hollow cylinder as shown earlier in Figure 1.5 and note down in Table 1.5
- When measuring the depth of the cavity, adjust the vernier caliper as shown in Figure 1.7 and take readings in three places. Note down readings in Table 1.6.

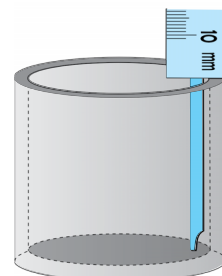

Figure 1.7

Readings and calculations

Least unit of vernier caliper –

Zero error of vernier caliper –

1. Measurements of wooden block

Table 1.1				
Corrected reading	(i)	(ii)	(iii)	Mean Value (cm)
length l (cm)				
breadth b (cm)				
height h (cm)				

2. Measurements of PVC tubing

Table 1.2				
Corrected reading	(i)	(ii)	(iii)	Mean Value (cm)
Internal diameter d_1 (cm)				
External diameter d_2 (cm)				

Table 1.3				
Corrected reading	(i)	(ii)	(iii)	Mean value (cm)
length (cm)				

3. Measurements of solid sphere

<i>Table 1.4</i>				
Corrected reading	(i)		(iii)	Mean value (cm)
Diameter of sphere d (cm)				

4. Measurements of hollow cylinder

<i>Table 1.5</i>				
Corrected reading	(i)	(ii)	(iii)	Mean value (cm)
Internal diameter d (cm)				

<i>Table 1.6</i>				
Corrected reading	(i)	(ii)	(iii)	Mean value (cm)
Depth l (cm)				

Calculate according to relevant theory.

Result

Record your results in accordance with the above calculations.

Discussion

Present your opinion about the concluded results and their errors and also your suggestions on obtaining more accurate results.

Note

It is important to read the zero error of a vernier calliper according to the position of its zero mark and also to decide whether the correction should be subtracted from or added to the relevant measurement.

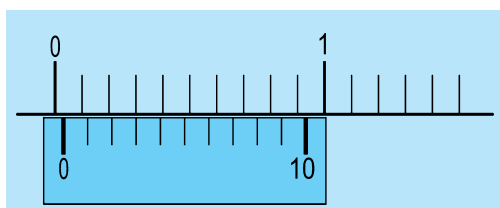

Figure 1.9

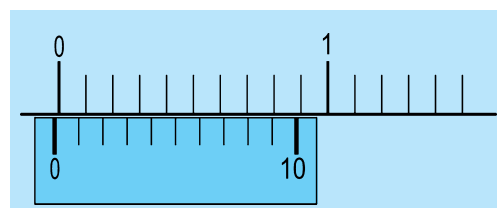

Figure 1.10

The above diagram illustrates how the zero error is indicated in two different vernier callipers when their vernier scales are adjusted to bring their jaws to touch each other.

According to Figure 1.9 the zero error (the gap between the zero of the vernier scale and that of the main scale) can be read directly from the scale. This value is 0.3 mm. The correct reading should be the distance moved by the vernier scale. The movement of the vernier scale starts from this position. But readings are recorded from the zero of the main scale. Hence for correction, this value (0.3 mm) should be subtracted from the relevant reading.

According to Figure 1.10, for zero error, the gap between the zero of the vernier scale and the zero of the main scale cannot be obtained directly from the readings shown on the scale. The gap of the vernier divisions up to the reading at coincidence should be found and from it the gap of the main scale divisions should be subtracted to find the zero error.

$$\text{zero error} = (8 \times 0.9 - 7.0) \text{ mm} = (7.2 - 7.0) \text{ mm} = 0.2 \text{ mm}$$

For correction this value (0.2 mm) should be added to the relevant reading.

A more convenient method exists to determine the zero error. The value corresponding to the reading at coincidence should be first subtracted from the sum of all divisions in the vernier scale and this value has to be multiplied by the least count of the vernier scale.

Accordingly,

$$\text{zero error} = (10 - 8) 0.1 \text{ mm} = 0.2 \text{ mm}$$

Usage of the micrometer screwgauge

1. Finding the diameter of a thin wire
2. Finding the diameter of a steel/ glass ball
3. Finding the thickness of a microscope slide
4. Finding the thickness of a photocopy paper

Materials and apparatus

A micrometer screwgauge (of about gauge 22), a thin wire, a steel ball (a ball bearing of about 5 mm), a microscope slide and a photocopy paper.

Theory

If x is the pitch of the screw and n the number of divisions on the circular scale, then,

$$\text{Least count of the instrument in relevant units} = \frac{x}{n}$$

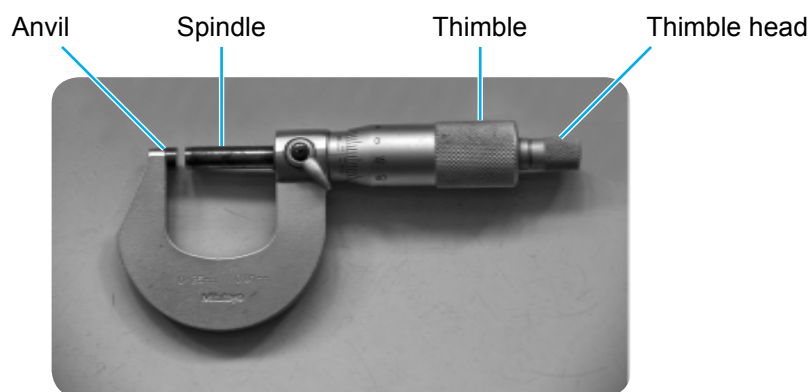

Figure 2.1 Micrometer screwgauge

Method

Obtain the least count of the micrometer screwgauge. Rotate holding thimble head only until the spindle touches the anvil (when the spindle touches the anvil or when these two are in contact with any other object the thimble head would rotate freely making a “ticking” sound) Note down any zero error if shown.

1. To measure the diameter of the wire place it between the anvil and the spindle and rotate the thimble head until the wire is held properly between those two. Obtain the value of the diameter. Rotate the wire by 90° and obtain reading again. Repeat these measurements for three places of the wire and enter the corrected readings in Table 2.1.

2. Arrange the ball to fit properly between the anvil and the spindle and obtain readings for three diameters normal to each other. Enter the corrected readings in Table 2.2.
3. Arrange the microscope slide to fit between the anvil and the spindle and obtain readings for thickness of the slide in three different places. Enter the corrected readings in Table 2.3.
4. Cut the photocopy paper into 20 pieces, place the pieces one over the other into a bundle and obtain readings for thickness of the bundle at three different places. Enter the corrected readings in Table 2.4.

Readings and calculations

Least count of the micrometer screwgauge –

Zero error –

<i>Table 2.1</i>					
Diameter of wire (mm)					Mean diameter (mm)
(i)	(ii)	(iii)			

<i>Table 2.2</i>					
Diameter of ball (mm)					Mean diameter (mm)
(i)	(ii)	(iii)			

<i>Table 2.3</i>					
Thickness of microscope slide (mm)					Mean thickness (mm)
(i)	(ii)	(iii)			

<i>Table 2.4</i>							
Corrected reading	Thickness of 20 pieces (mm)					Mean thickness of 20 pieces (mm)	Mean thickness of paper (mm)
	(i)	(ii)	(iii)				

Results

Record your results according to the above calculations.

Discussion

Present your opinions about the concluded results and their errors and also your suggestions for obtaining more accurate results.

Note

It is important to read the zero error according to the position of the zero of the circular scale related to the line of the main scale of a micrometer screwgauge and also to decide whether for correction this value should be subtracted from or added to the relevant measurement.

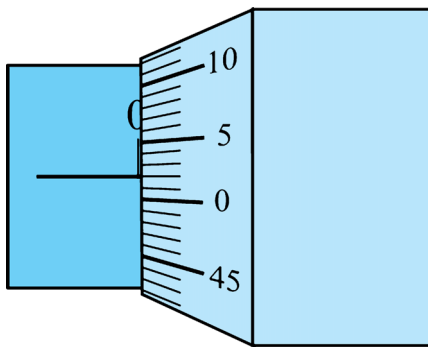

Figure 2.2

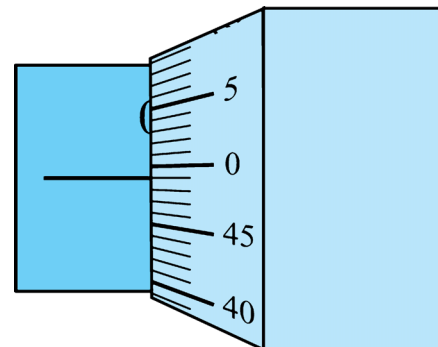

Figure 2.3

Above figures illustrate two ways of indicating the zero error in two micrometer screwgauges when the thimble heads are rotated to bring the anvil and the spindle to touch each other.

According to Figure 2.2 the zero error (the gap between the main scale line and the zero of the circular scale) is 0.02 mm. Accordingly the zero of the circular scale is situated below the main scale line. The rotation of the circular scale begins from 0.01 mm. Hence for correction this value should be subtracted from the relevant reading.

According to Figure 2.3 the zero of the circular scale is situated above the main scale line. Accordingly the zero error is 0.01 mm. The zero of the circular scale will coincide with the main scale line only when it is rotated by 0.01 mm towards the main scale line. Hence for correction this value should be added to the relevant reading. When measuring the thickness of a photocopy paper the number of paper pieces should be selected to obtain a thickness reading so that the percentage error with respect to the least count of the instrument is less than or equal to 1%.

Usage of the spherometer

1. Finding the thickness of a microscope slide
2. Finding the radius of curvature of a spherical surface

Materials and apparatus

a spherometer, plane (optically flat) piece of glass, a microscope slide and a clock glass and a metre ruler or a vernier calliper

Theory

If the screw pitch of the spherometer is x and the number of divisions of the circular scale is y , then

$$\text{Least count} = \frac{x}{y}$$

If h is the height from the plane of the leg tips up to the point at which the screw tip touches the curved surface, a the gap between the two legs of the spherometer and R the radius of curvature of the spherical surface,

$$R = \frac{a^2}{6h} + \frac{h}{2}$$

Vertical scale Circular scale

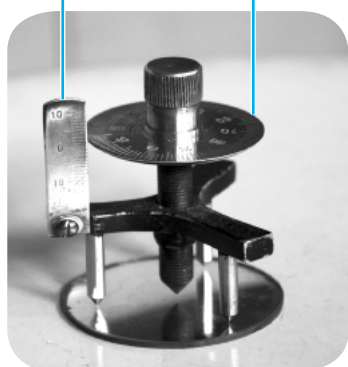

Figure 3.1 Spherometer

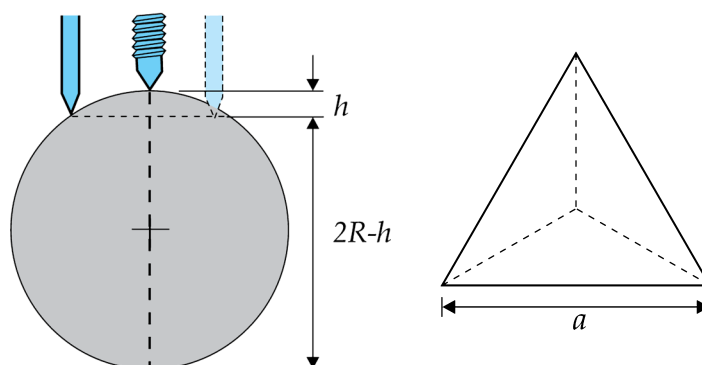

Figure 3.2

Method

Find the least count of the spherometer. Place the three legs of the spherometer on the plane glass surface and screw the central leg until its tip touches the glass surface. This can be done by making the screw tip to come into contact with its own image formed by partial reflection on the glass surface. Obtain and note down the reading corresponding to the position of the screw tip using the readings of the vertical scale and the circular scale.

1. Raise the screw a little and insert the microscope slide on the glass surface below the screw. Turn the screw until the screw tip touches the upper surface of the slide and observe the reading. Take similar readings on three spots of the slide. Record the difference between the reading obtained on the plane glass surface and these three readings on the Table 3.1.

- Place three legs of the spherometer on the spherical surface and adjust the screw for the screw tip to touch the spherical surface as shown in Figure 3.2. Observe the relevant reading and record the difference between this reading and the reading on the plane glass surface as h .

Place the spherometer on a paper and press on it. Measure using the tips of the internal jaws of a vernier calliper the distance between the marks made by the spherometer legs on the paper. Instead a metre ruler also could be used.

Readings and calculations

Reading when the screw tip touches the plane of the legs –

Table 3.1			
Thickness of microscope slide (mm)			Mean thickness (mm)
(i)	(ii)	(iii)	

Value of h = mm
 Distance between the two legs of the spherometer (a) = (i) ... mm, (ii) ... mm, (iii) ... mm
 Mean value of a = mm

Calculate the radius R of of the clock glass using the theory.

Result

Record your results according to the above calculations.

Discussion

Present your opinions about the concluded results and their errors and also suggestions to obtain more accurate results.

Note

Depending on whether the surface is convex or concave, decide whether the first reading (the reading when the screw tip is on the plane of the leg tips) should be subtracted from or added to the second reading (when the screw tip is touching the curved surface.)

Care should be taken to read the reading on the circular scale according to the sense of rotation of the same scale. The reading on the scale can be taken directly as the correct reading if the circular scale is rotated anti-clockwise. If the circular scale is rotated clockwise, the reading on the circular scale has to be subtracted from the total number of divisions on the circular scale.

Usage of the travelling microscope

1. Finding the internal diameter of a capillary tube
2. Finding the internal diameter of a rubber tube
3. Finding the external diameter of a rubber tube

Materials and apparatus

A travelling microscope, a capillary tube, a rubber tube, a stand and a spirit level

Theory

In an instrument with vernier scales, if n divisions of the main scale coincides with N divisions of the vernier scale, then,

$$\text{Least count} = \left(1 - \frac{n}{N}\right) \times \text{length of a smallest division of the main scale}$$



Figure 4.1 Travelling microscope

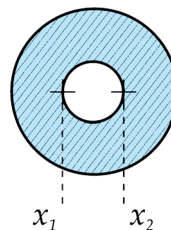

Figure 4.2

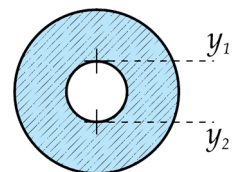

Figure 4.3

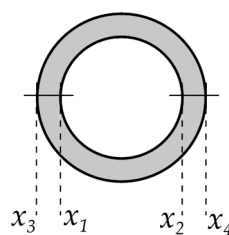

Figure 4.4

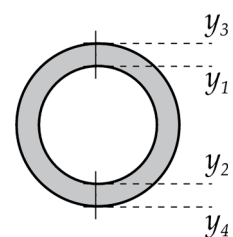

Figure 4.5

Method

First determine the least count of the travelling microscope and note it down. Using a spirit level and adjusting the levelling legs, level the microscope.

Fix the capillary tube co-axially with the microscope part of the instrument on a stand and focus the face of the capillary tube by the microscope.

Move the microscope horizontally until the cross wires of the microscope get adjusted as shown in Figure 4.2 and using the horizontal scale observe readings X_1 and X_2 . Next move the microscope vertically until its cross wires get adjusted as shown in Fig 4.3 and using the vertical scale observe readings Y_1 and Y_2 . Record your readings in Table 4.1.

Remove the capillary tube, insert the rubber tube in that position. measure the internal horizontal diameter of the tube as shown in Figure 4.4 and obtain readings X_1 and X_2 . Next obtain the internal vertical diameter of the tube as shown in Figure 4.5 and obtain readings Y_1 and Y_2 . Enter all these readings in the Table 4.2

When measuring the external diameter of the rubber tube arrange it so that the cross wires are in contact with its external surface and obtain readings X_3 and X_4 as shown in Figure 4.4. and also readings Y_3 and Y_4 as shown in Figure 4.5. Enter the readings in Table 4.3

Readings and calculations

Table 4.1				
X_1 (cm)	X_2 (cm)	Y_1 (cm)	Y_2 (cm)	Mean internal diameter of the capillary tube (cm)

Table 4.2					
X_1 (cm)	X_2 (cm)	Y_1 (cm)	Y_2 (cm)	Internal diameter of rubber tube (cm)	Mean internal diameter of rubber tube (cm)

Table 4.3					
X_3 (cm)	X_4 (cm)	Y_3 (cm)	Y_4 (cm)	External diameter of rubber tube (cm)	Mean external diameter of rubber tube (cm)

$$\text{Mean internal diameter of capillary tube} = \frac{(X_2 - X_1) + (Y_2 - Y_1)}{2}$$

$$\text{Mean internal diameter of rubber tube} = \frac{(X_2 - X_1) + (Y_2 - Y_1)}{2}$$

$$\text{Mean external diameter of rubber tube} = \frac{(X_4 - X_3) + (Y_4 - Y_3)}{2}$$

Conclusion

Record your conclusions in accordance with the above calculations.

Discussion

Present your opinions about the above conclusions and their errors and also your suggestions about obtaining these values accurately.

Note

Use a rubber tubing of about 5 cm in length and 5 mm diameter. Insert into the tube a cylindrical piece of wood of slightly smaller diameter than that of the rubber tubing to facilitate the fixing of the tube horizontally.

When using the travelling microscope it is convenient to have a knowledge of the effective length (focusing length) of the microscope to perform the experiment. This value is mentioned in the trunk of the instrument and if not the microscope can be focused onto a square ruled paper and the distance between the paper and the eye piece end of the microscope can be measured.

Focusing can be done with ease by placing in line the end of the rubber tube or the capillary tube at this distance.

Verification of the law of parallelogram of forces and using it to determine the mass of a body

Materials and apparatus

Parallelogram of forces apparatus, an object (a small stone or a glass stopper) of unknown mass, three known loads, a set square or a short plane mirror strip, a half metre ruler, pins, an A4 white paper and a three beam balance.

Theory

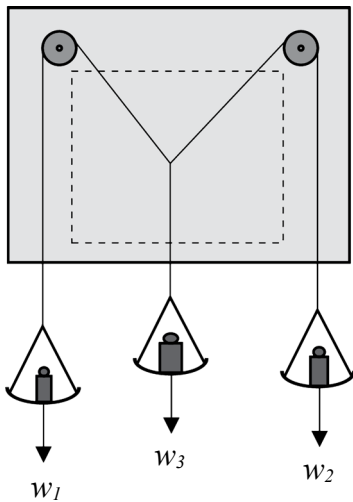

Figure 5.1

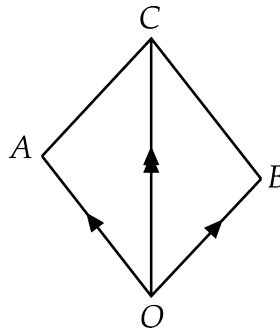

Figure 5.2

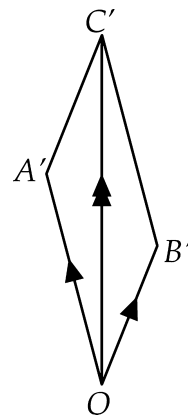

Figure 5.3

Verification of the law of parallelogram of forces

Once the parallelogram $OABC$ is constructed using a suitable scale, if the value of the product of the length OC of diagonal and the scale value is equal to the value of the load w_3 and also if diagonal OC stays vertically then the law of parallelogram of forces is verified.

Determination of the mass of a body (load w_3')

Once the parallelogram $OA'C'B'$ is constructed using a suitable scale, the value of the product of length OC' of the diagonal and the scale value will be equal to the value of the mass of w_3' .

Method

Fix the paper on the board. Place loads w_1 , w_2 and w_3 on the balance pans. Pull down middle load a little and release and test whether it returns to the original position. By placing the set square normal to the strings or the plane mirror strip below the string till the string covers its own image and then mark on the paper by two dots the projection of each string. Remove the paper from the board and draw lines across the dots marked on the paper. Measure the masses of the pans and

add to the relevant loads. Choosing a suitable scale draw OA and OB with lengths proportional to the values of w_1 and w_2 respectively. complete the parallelogram $OACB$ and measure the length of diagonal OC . Confirm the validity of the law of parallelogram of forces in accordance with the above theory.

Remove load w_2 and place the given body (load w) on it. Repeat the experiment as before and using the same scale, construct the parallelogram $OA'B'C'$ and measure the length of the diagonal OC' . deduce the mass of the given body in accordance with the theory.

Readings and calculations

Scale used =

Length of diagonal OC = cm

Length of diagonal OC' = cm

Calculate the mass of the body according to theory.

Result

Confirm the law of parallelogram of force from the results of the first experiment. Record the mass of the given body obtained from the result of the second experiment.

Discussion

Measure the mass of the body using a balance and find the percentage of error of the value obtained from the experiment. If there is any deviation provide reasons.

Note

Law of parallelogram of forces

If two forces acting on a point can be represented in magnitude and direction by two adjacent sides of a parallelogram, then the resultant of the two forces will be represented in magnitude and direction by the diagonal of the parallelogram passing through that angular point.

After placing the loads on the pans of the parallelogram law apparatus the load on the middle pan is pulled down and released to test for friction. If the pan does not return to its original position indicating the presence of friction, application of a lubricant would minimize it.

If the strings have weight their weights too get added to the relevant loads reducing the accuracy of the results. Weightlessness of the strings would add to the accuracy of the results of the experiment.

Determination of the mass of a body using the principle of moments

Materials and apparatus

A metre ruler, a knife edge, a 50 g weight, a glass stopper or a small stone (of about 50 g mass), a piece of string and a block of wood (3" × 4")

Theory

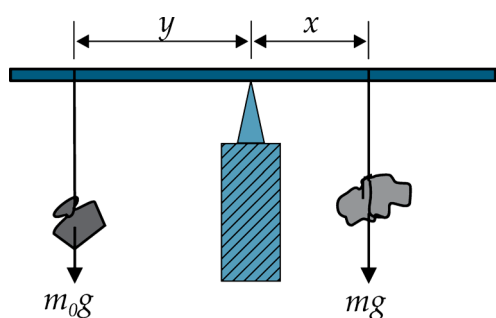

Figure 6.1

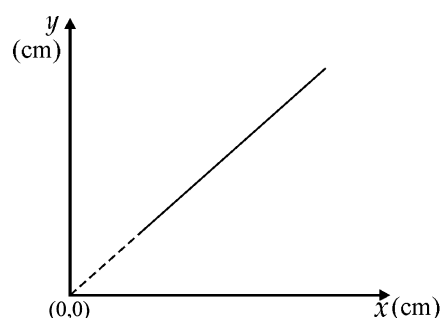

Figure 6.2

- m_0g - Known load
 mg - weight of unknown body

In the position of equilibrium, according to the principle of moments,

$$m_0g \times y = mg \times x$$

$$y = \left(\frac{m}{m_0} \right) x$$

$$\text{Gradient of the graph of } y \text{ against } x = \frac{m}{m_0}$$

$$\therefore m = \text{gradient} \times m_0$$

Method

Place the knife edge on the stand and on it balance the metre ruler horizontally. As shown in Figure 6.1 suspend the known mass m_0 and the unknown mass m on opposite sides of the knife edge and adjust length y keeping length x at a selected value until the ruler is balanced horizontally. Measure the values x and y .

Repeat the experiment for five other selected values of x so as to obtain a wide spread of readings. Enter the readings in the Table 6.1. When taking readings take care to keep the balancing point of the ruler on the knife edge unchanged at the original position.

Readings and calculations

<i>Table 6.1</i>						
x (cm)						
y (cm)						

Plot y against x .

Calculate the gradient of the graph and using the theory find the mass of the given body.

Result

Record the mass of the body as found from the results of the experiment.

Discussion

Measure the mass of the body using a balance and calculate the percentage error of experimental value. Explain with reasons of any deviations.

Determination of the relative density of a liquid using the U tube

Materials and apparatus

A U tube, two half-metre rulers, coconut oil, water, clamp stands and a set square

Theory

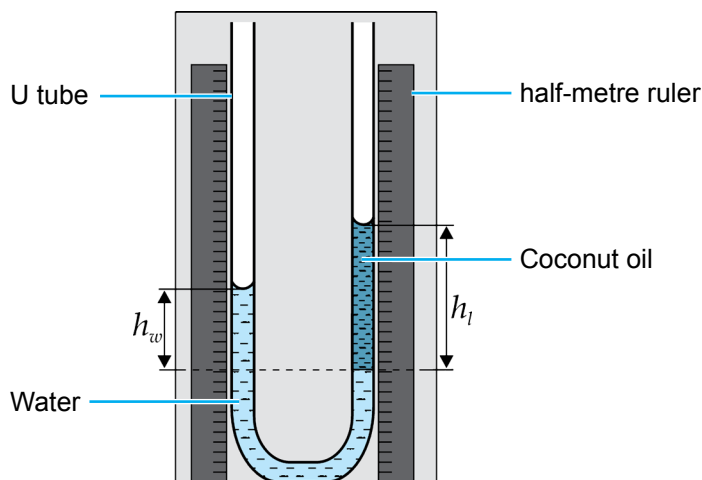

Figure 7.1

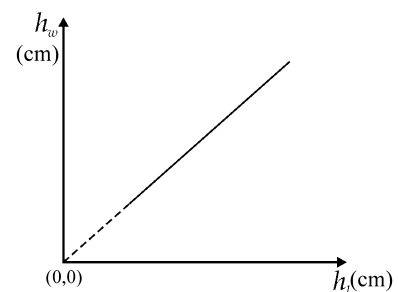

Figure 7.2

If h_w is the height of the water column and h_e the height of the liquid column from the common interface level, ρ_w and ρ_l the densities of water and liquid respectively and p_0 the atmospheric pressure, then,

$$p_0 + h_w \rho_w g = p_0 + h_l \rho_l g$$

$$h_w = \left(\frac{\rho_l}{\rho_w} \right) h_l$$

Gradient of the graph h_w against $h_l = \frac{\rho_l}{\rho_w} = \text{Relative density of liquid}$

Method

Attach the U tube vertically on to the stand. Fix close to this the vertical limbs the half-metre rulers on to the stand. Pour a certain quantity of water (liquid of higher density) into one limb of the U tube and then pour into the other limb another quantity of coconut oil. Using the set square obtain respective readings (x and y) for water meniscus and liquid meniscus and then the reading (z) corresponding to the oil / water interface correctly. Adding more of coconut oil (with lesser density) in small quantities into its limb, obtain about six sets of readings of x , y and z . Enter the readings in the Table 7.1.

Readings and calculations

x (cm)						
y (cm)						
z (cm)						
$h_l = (y - z)$ (cm)						
$h_w = (x - z)$ (cm)						

Plot h_w against h_l .

Calculate the gradient of the graph and from it obtain the relative density of the liquid.

Results

Use the results of the experiment to deduce the value of the relative density of liquid.

Discussion

The set square can be used for accurate determination of the reading relevant to the bottom of the liquid meniscus.

If the liquid of lower density (coconut oil) is poured first into the U tube then when water is poured coconut oil would creep on to the top of the water meniscus causing experimental errors. Hence the liquid of higher density (water) should be poured first into the U tube.

Note

When pouring coconut oil care should be taken to prevent the common interface entering the curved portion of the U tube.

Determination of the relative density of a liquid using Hare's apparatus

Materials and apparatus

Hare's apparatus, a plastic syringe of about 15 cm, water and a copper sulphate solution or any other suitable solution, a half-metre ruler and a set square.

Theory

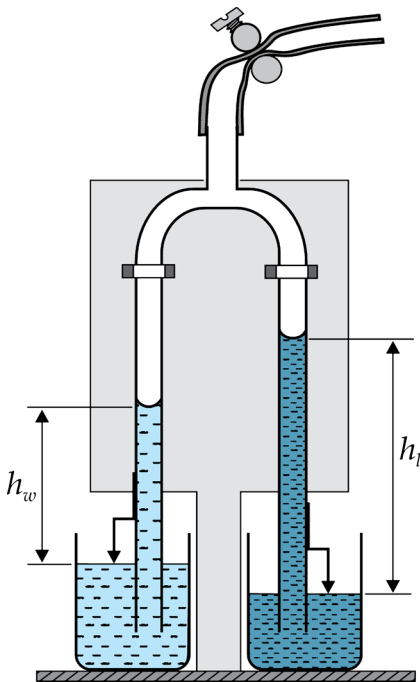

Figure 8.1

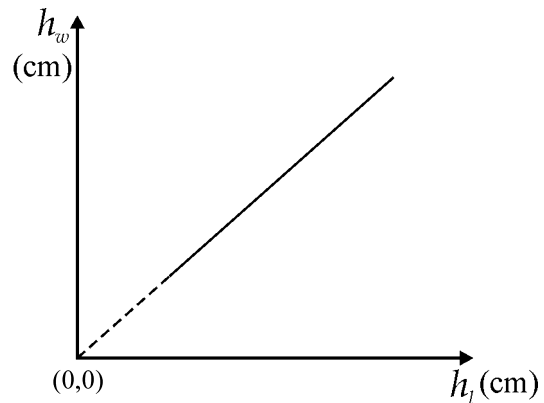

Figure 8.2

- h_w – height of water column above water level of beaker
 h_l – height of liquid column above liquid level of beaker
 ρ_w – density of water
 ρ_l – density of liquid

If p_0 is the atmospheric pressure and p the pressure of air in the tube,

$$\begin{aligned}
 p_0 &= p + h_w \rho_w g &= p + h_l \rho_l g \\
 h_w \rho_w &= h_l \rho_l \\
 h_w &= \left(\frac{\rho_l}{\rho_w} \right) h_l
 \end{aligned}$$

Gradient of the graph h_w against $h_l = \frac{\rho_l}{\rho_w} =$ relative density of liquid

Method

Arrange Hare's apparatus as shown in Figure 8.1 with its limbs having ends dipped into water and liquid beakers. Open the clip and suck air out either by mouth or by the syringe to form a water column and a liquid column in the respective limbs (until the liquid column of lower density reaches maximum height) and then close the clip. Adjust each index until its tip touches the respective liquid level. With the help of the set square and using scales measure height h_w of water column and height h_l of liquid column and record these readings. Loosening the clip slightly and again tightening it alternatively obtain a set of values of h_w and h_l and record these values in the Table 8.1

Readings and calculations

Table 8.1						
Height of water column (cm)						
Height of liquid column (cm)						

Plot h_w against h_l

Calculate the gradient of the graph and using it obtain the relative density of the liquid.

Conclusion

Conclude the value of the relative density of the liquid obtained from experimental results.

Discussion

State the methodology of using simple measuring instruments to measure accurately the heights of liquid columns.

Note

If a Hare's apparatus with indexes is used for this experiment, the theory as well as the method of obtaining readings should be altered accordingly. After making the water and liquid columns to be stationary adjust the tips of the indexes to touch the water and liquid surfaces in the beakers. Measure height h'_w of the water column and the height h'_l of the liquid column from the tip of each index.

If ρ_w and ρ_l are the densities of water and liquid respectively, p_0 the atmospheric pressure, and p the pressure of the air in the tube,

$$\begin{aligned}
 p_0 &= p + (h'_w + x_1) \rho_w g &= p + (h'_l + x_2) \rho_l g \\
 &(h'_w + x_1) \rho_w &= (h'_l + x_2) \rho_l \\
 h'_w &= \left(\frac{\rho_l}{\rho_w} \right) h'_l + \frac{l}{\rho_w} (x_2 \rho_2 - x_1 \rho_w)
 \end{aligned}$$

Gradient of the graph h'_w against $h'_l = \frac{\rho_l}{\rho_w} =$ relative density of the liquid

Determination of the density of a liquid using a weighted test tube

Materials and apparatus

A boiling tube, a tall jar, a few mass units, a vernier calliper, a graph paper strip marked in millimetres, a sufficient amount of a solution of sodium chloride, lead shots / small iron balls (bicycle) and a small quantity of wax.

Theory

- V – volume of the portion in the tube filled with wax
 M – mass of the tube with its contents
 A – external area of the cross section of the cylindrical portion of the tube
 m – mass of additional weights inserted into the tube
 ρ – density of the liquid
 l – length of the cylindrical portion (above wax level) immersed in the liquid when the tube floats in a liquid

According to the principle of floatation

$$(M + m)g = (V + Al)\rho g$$

$$l = \left(\frac{1}{A\rho}\right)m + \frac{1}{A}\left(\frac{M}{\rho} - V\right)$$

If G is the gradient of the graph of l against m ,

$$G = \frac{1}{A\rho}$$

If d is the external diameter of the tube,

$$A = \frac{\pi d^2}{4}$$

$$\rho = \frac{4}{\pi d^2 G}$$

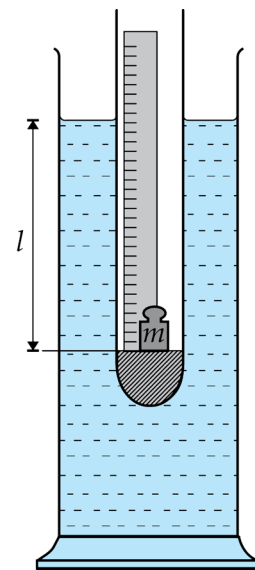

Figure 9.1

Method

Put the minimum amount of lead shots that would make the boiling tube float vertically in the liquid. Pour wax into the tube until the lead shots are completely covered (the spherical portion of the tube should be filled with wax). Paste the paper strip on the inner wall so that the zero of the scale begins from the lower end of the cylindrical portion (Figure 9.1). Fill the tall jar with the liquid

(sodium chloride), make the tube float vertically- in it and record the length l of the tube immersed in liquid. Insert one mass unit (m) into the tube and record the corresponding l value. increase m and obtain about six values. Record the readings in the Table 9.1. Measure the external diameter of the tube using a vernier calliper at three different places of the tube taking three readings normal to each other at each place.

Readings and calculations

m (g)						
l (cm)						

	External diameter of tube (cm) at the selected location	Mean external diameter of tube (cm) at that location	Mean external diameter of tube (cm)
(i)			
(ii)			
(iii)			

Plot l against m .

Calculate the gradient of the graph.

Calculate the density of the liquid as explained in the theory.

Result

Using the results find the density of the liquid.

Discussion

Discuss the precautional measures to be taken to increase the accuracy of the results obtained in the experiment.

Note

Determine first the maximum mass that could be inserted into the tube to immerse it in the liquid while adding weights from a small value until its open end reaches the liquid level. Divide this value of the maximum mass into six equal values and obtain readings by adding each time a mass equal to this value into the tube. This would enable to obtain a good spread among the readings.

Sufficient lead shots are put into the tube to float the tube vertically and wax is poured to cover it completely. Care should be taken to pour wax to fill completely the hemispherical portion of the tube as shown in Figure 9.1

When using a box of weights for the experiment it may become necessary to remove some added weights. This inconvenience can be avoided by arranging equal mass units.

Determination of the acceleration due to gravity using the simple pendulum

Materials and apparatus

A simple pendulum, a metre ruler, a stop watch, a locating pin and a cork cut vertically in the middle

Theory

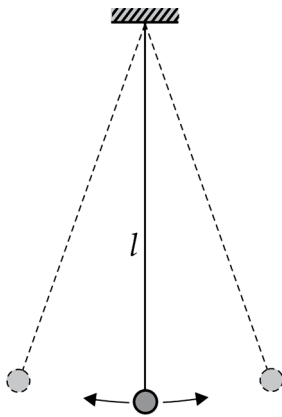

Figure 10.1

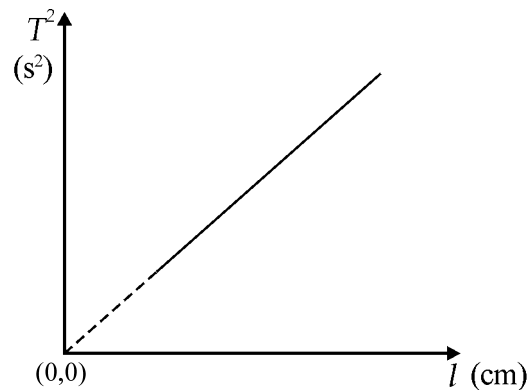

Figure 10.2

If l is the oscillating length and T the period of oscillation, of the simple pendulum,

$$T = 2\pi \sqrt{\frac{l}{g}}$$

$$T^2 = \left(\frac{4\pi^2}{g} \right) l$$

$$\text{Gradient of the graph } T^2 \text{ against } l = \frac{4\pi^2}{g}$$

$$g = \frac{4\pi^2}{(\text{gradient})}$$

Method

Pass the pendulum string through the cork and suspend the pendulum from a stand. Measure the oscillating length l of the pendulum from the point of suspension down to the centre of the pendulum bob. Note down the value of l and fix the locating pin vertically below and close to the lowest point of the path of pendulum bob. Pull the bob aside till it is inclined by a small angle to the vertical (5° or 6°) Release the pendulum to make it oscillate in a vertical plane and using the stop watch measure the time for 25 oscillations. Record the time and repeat the experiment by increasing the value of l by 10 cm after starting from about $l = 40$ cm. Obtain about six recordings and enter the values in the Table 10.1.

Readings and calculations

Table 10.1						
l (cm)						
Time for 25 oscillations (s)	(i)					
	(ii)					
T (s)						
T^2 (s ²)						

Plot T^2 against l and calculate the gradient of the graph.
Calculate the value of g as explained in the theory.

Result

Conclude the value of 'g' determined from the results of the experiments. as the acceleration due to gravity

Discussion

Considering that the value of 'g' in Sri Lanka is 9.78 m s^{-2} , find the percentage error of the value you obtained with your experiment.

Note

Select the number of oscillations so that according to the least count of the stopwatch the percentage error of the measurement is 1%.

The formula $T = 2\pi \sqrt{\frac{l}{g}}$ is valid only when the angle of oscillation is small.

When oscillating the bob at a small angle, take care to make oscillations in a vertical plane. It would be an approximate elliptical motion.

In order to activate the stop watch when the pendulum bob passes the locating pin, start counting in the descending order.

eg. : 3, 2, 1, 0, 1, 2, , 25

Start counting from 3 when the bob passes the locating pin and activate the stop watch when counting 0. When the person who starts the stop watch gets used to this rythem the personal error becomes minimal.



Verification of the relationship between the mass of a body suspended from a helix spring and its period of oscillation

Materials and apparatus

A helix spring, a set of 50 g weights, a stop watch, a locating pin and a stand

Theory

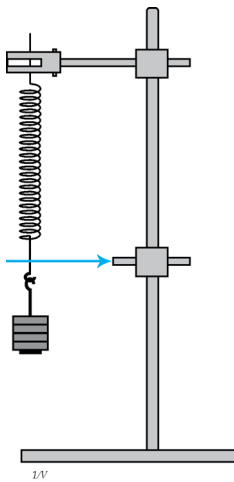

Figure 11.1

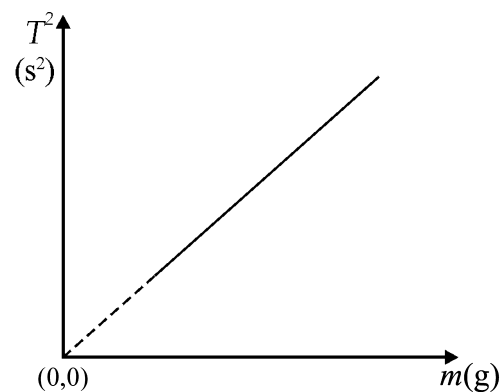

Figure 11.2

If the suspended mass is m , the spring constant of the spring is k and the period of oscillation is T ,

$$T = 2\pi \sqrt{\frac{m}{k}}$$

$$T^2 = \left(\frac{4\pi^2}{k} \right) m$$

If the graph of T^2 against m is a straight line through the origin, the relation $T^2 \propto m$ is verified.

Method

Suspend helix spring vertically from a fixed stand as shown in Figure 11.1 and from the lower end of the spring hang the initial weight of the set of weights (the dark portion). Attach an indicator horizontally to the end of the spring. When the spring is at rest and close to its path of oscillation as shown in Figure 11.1, connect the locating pin to the stand in line with the indicator.

Pull down the suspended weight slightly and release it to make it oscillate in a vertical plane. Measure the time taken for 50 oscillations using the stopwatch. Obtain this measurement again. Repeat the experiment by increasing m for about six values of m and record the values in the Table 11.1.

Readings and calculations

m (g)							
Time for 50 oscillations (s)	(i)						
	(ii)						
T (s)							
T^2 (s ²)							

Plot T^2 against m .

Conclusion

Verify the relationship between mass and periodic time of the helix spring making use of the shape of the graph of T^2 against m .

Note

Select the number of oscillations so that the percentage error of the measurement obtained according to the least count of the stopwatch and the rigidity of the helix spring is 1%.

The formula $T = 2\pi \sqrt{\frac{m}{k}}$ is valid only when the displacement is small.

Determination of the frequency of a tuning fork using the sonometer

Materials and apparatus

A sonometer, a tuning fork of unknown frequency, a set of 0.5 kg weights, a light paper rider, a piece of the sonometer wire, a metre ruler and a three beam balance

Theory

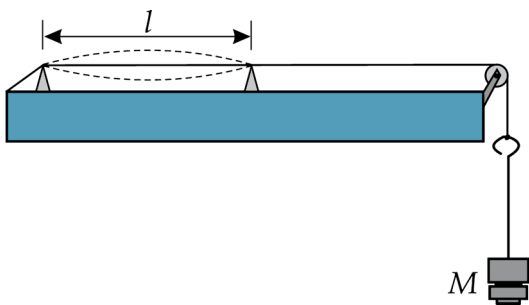

Figure 12.1

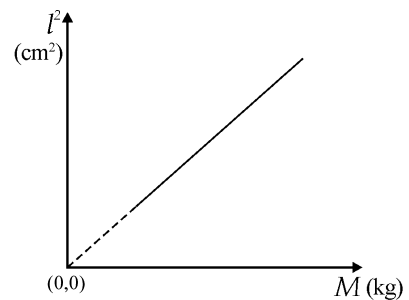

Figure 12.2

If f is the resonance frequency, l the resonance length, T the tension and m the mass of a unit length of the sonometer wire,

$$f = \frac{1}{2l} \sqrt{\frac{T}{m}}$$

If M is the mass hang from the sonometer wire,

$$T = Mg$$

$$f = \frac{1}{2l} \sqrt{\frac{Mg}{m}}$$

$$l^2 = \left(\frac{g}{4f^2 m} \right) M$$

$$\text{Gradient of the graph of } l^2 \text{ against } M = \frac{g}{4f^2 m}$$

$$\therefore f = \left(\frac{g}{4m (\text{gradient})} \right)^{1/2}$$

Method

Suspend an initial load of 0.5 kg from the sonometer wire that passes over the pulley. Arrange the bridges to have a small gap between them and place the light paper rider in the middle of the wire over the bridges. Vibrate the given tuning fork and place it on the sonometer. Pull the two bridges

apart to increase the gap until the rider is instantly thrown out of the wire. Obtain the fundamental resonance situation in this manner and note down the value M of the suspended mass and also the length l of the sonometer wire between the bridges.

Increasing the value of M by 0.5 kg each time and repeating the experiment obtain about six more relevant values of l . Record the readings in the Table 12.1. In order to determine the value of m (the mass per unit length of the wire) measure the length of the piece of sonometer wire by the metre ruler and its mass by the three beam balance.

Readings and calculations

Table 12.1					
M (kg)					
l (cm)					
l^2 (cm ²)					

Length of the piece of wire = cm

Mass of the piece of wire = cm

Plot l^2 against M and calculate the gradient of the graph.

Calculate the value of m .

Calculate the value of f as explained in the theory.

Result

Use the results of the experiment to find the frequency of the tuning fork.

Note

When the vibrating tuning fork is placed close to the midpoint between the bridges of box, transmission of energy takes place well and this makes it easy to obtain resonance.

The following methods also could be employed to obtain resonance between the sonometer wire and the vibrating tuning fork.

(i) Tuning by hearing.

Keep on vibrating the tuning fork and the portion of the wire between bridges together. Starting from a small value increase the gap between the bridges until the two sounds are heard to be in tune.

(ii) Tuning using beats.

Vibrate the tuning fork and the wire between the bridges together and starting from a small value increase the gap between the bridges until the beats are heard. Then adjust the gap further until beats vanish indicating resonance.

Verification of the relationship between the frequency of a stretched string and its vibrating length using the sonometer

Materials and apparatus

A sonometer, a set of weights, a 2 kg weight and a light paper rider

Theory

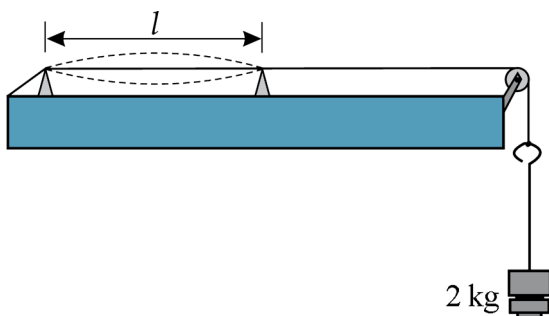

Figure 13.1

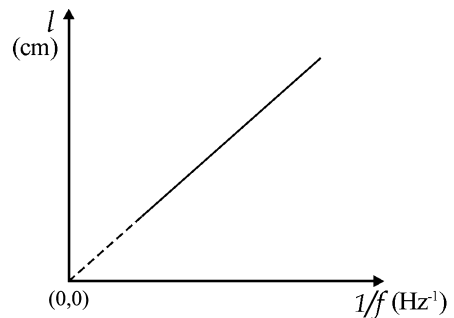

Figure 13.2

If f is the resonance frequency of the wire, l the resonance length, T the tension and m the mass per unit length of wire,

$$f = \left(\frac{1}{2l} \sqrt{\frac{T}{m}} \right)$$

$$l = \left(\frac{1}{2} \sqrt{\frac{T}{m}} \right) \frac{1}{f}$$

If the graph of l against $\frac{1}{f}$ is a straight line through the origin, the relation,

$$l \propto \frac{1}{f} \text{ is verified.}$$

Method

Suspend an initial load of 2 kg from the wire that passes over the pulley fixed to the sonometer. Arrange the bridges to have a small gap between them and place the paper rider on the middle of the wire between the bridges. Select the tuning fork of highest frequency since it would give the shortest resonance length. Vibrate this tuning fork and hold it on the sonometer box. Next increase the gap between the bridges until the rider gets thrown out of the wire. Measure the length l of the wire between bridges and note down the value along with frequency f of the fork. Repeat the process by selecting the tuning forks in the descending order of frequencies and obtain about six sets of values of f and relevant l values. Enter the readings in the Table 13.1.

Readings and calculations

<i>Table 13.1</i>					
f (Hz)					
l (cm)					
$\frac{1}{f}$ (Hz ⁻¹)					

Plot l against $\frac{1}{f}$.

Result

According to the shape of your graph verify the relationship between the frequency of the wire and its vibrating length.

Note

Follow the methodology mentioned in the experiment no. 12 to obtain resonance accurately.

Determination of the velocity of sound using a closed resonance tube and a tuning fork and also determination of the end correction of the tube

Materials and apparatus

A tube of diameter about 2.5 cm and length about 50 cm, a tuning fork of known frequency, a metre ruler, a tall jar and a stand.

Theory

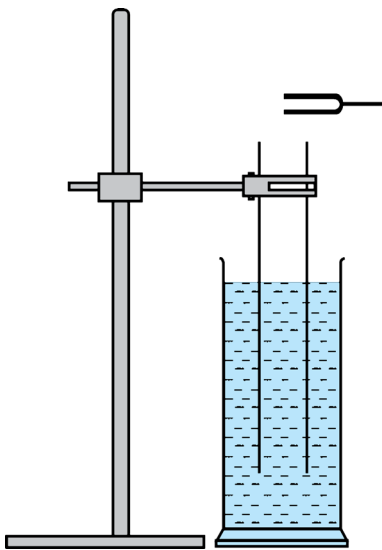

Figure 14.1

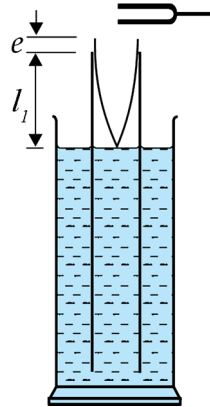

Figure 14.2

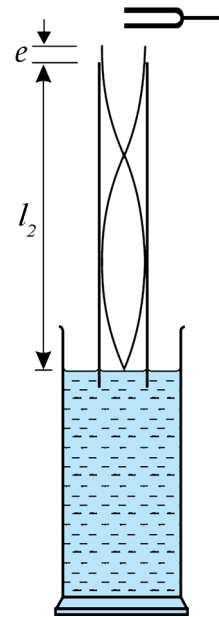

Figure 14.3

A closed tube when resonating at the fundamental let λ be the wavelength of the wave, l the resonating length of the tube and e the end correction of the tube.

$$\text{Then } \frac{\lambda}{4} = l_1 + e$$

If V is the velocity of sound and ' f ' the frequency of the fundamental note,

$$\begin{aligned} v &= f\lambda \\ v &= 4f(l_1 + e) \quad \text{----- (1)} \end{aligned}$$

If l_2 is the resonance length of the first overtone

$$\begin{aligned} \frac{3}{4} \lambda &= l_2 + e \\ v &= \frac{4}{3} f(l_2 + e) \quad \text{----- (2)} \end{aligned}$$

From (1) and (2) $v = 2f(l_2 - l_1)$

$$e = \frac{l_2 - 3l_1}{2}$$

Method

Immerse the tube in the water contained in the jar and fix it to the stand as shown in Figure 14.1. Arrange for a short length of air column in the tube, hold the vibrating tuning fork just about the upper end of the tube and raise the tube along with the fork until an intense sound is heard for the first time indicating fundamental resonance. Using the metre ruler measure length l_1 of air column. Hold the vibrating tuning fork again above the tube and raise it further to obtain the next state of resonance (first overtone). Measure the relevant length l_2 of the air column and enter these readings in the Table 14.1.

Readings and calculations

Frequency of the tuning fork f (Hz)	l_1 (cm)	l_2 (cm)

Calculate the velocity of sound in air (v) and the end correction (e) of the tube as explained in the theory.

Conclusion

Conclude the values of the velocity of sound in air and the end correction according to your calculation.

Discussion

Obtain the velocity of sound at the existing temperature from a data book and discuss the deviation of this value with the value you obtained from the experiment.

Determination of the velocity of sound in air using a closed resonance tube and a set of tuning forks and also determination of the end correction of the tube

Materials and apparatus

A tube of diameter about 2.5 cm and length about 50 cm, a set of tuning forks of known frequencies, a half metre ruler, a tall jar and a stand.

Theory

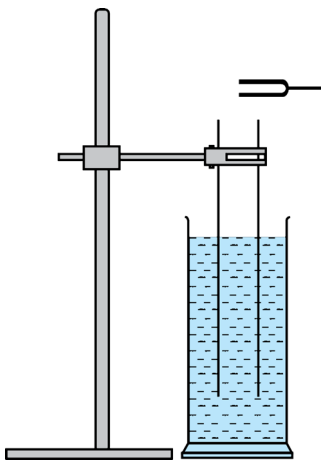

Figure 15.1

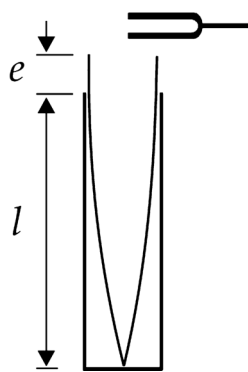

Figure 15.2

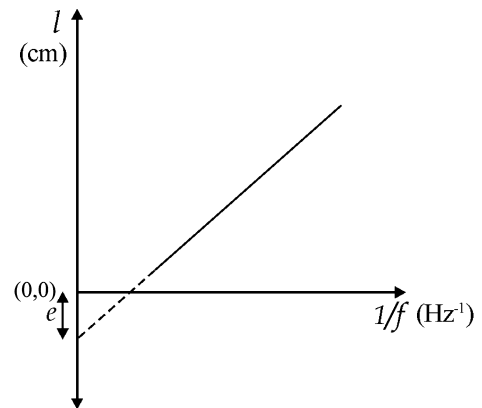

Figure 15.3

When a closed tube is resonating at the fundamental, let λ be the wavelength of the wave, l the length of the resonating air column and e the end correction of the tube.

$$\text{Then } l + e = \frac{\lambda}{4}$$

If v is the velocity of sound in air and f the frequency of the fundamental note,

$$\lambda = \frac{v}{f}$$

$$l = \left(\frac{v}{4}\right)\frac{1}{f} - e$$

Gradient of the graph of l against $\frac{1}{f} = \frac{v}{4}$

$$v = \text{gradient} \times 4$$

$$e = \text{intercept}$$

Method

As shown in Figure 15.1 immerse the tube vertically in the water contained in the jar leaving a small length of the air column and fix the tube on to the stand. Select the tuning fork of highest frequency from the set, vibrate it and hold it just above the open end of the tube. Then raise the tube and the tuning fork together until a louder sound is heard for the first time indicating fundamental resonance. Measure the length l of the air column above the level of water in the tube and note it along with the frequency f of the tuning fork.

Selecting the other tuning forks in the descending order of frequencies, obtain fundamental resonance length l relevant to the frequency f of the tuning fork used as done above and after obtaining about five sets of readings record the values in the Table 15.1 given below.

Readings and calculations

f (Hz)					
l (cm)					
$\frac{1}{f}$ (Hz ⁻¹)					

Plot l against $\frac{1}{f}$ and calculate the gradient of the graph.

Also obtain the intercept on the y -axis.

Calculate the velocity of sound in air and also the end correction of the tube. from the gradient and the intercept as explained in the theory

Conclusion

Conclude the values of velocity of sound in air and the end correction of the tube you have calculated.

Discussion

Conduct the discussion as you did in experiment no 14.

Determination of the refractive index of glass using the travelling microscope and a block of glass

Materials and apparatus

A travelling microscope, a rectangular glass block, a white sheet of paper and some lycopodium or any other suitable powder

Theory

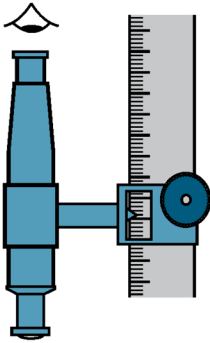

Figure 16.1

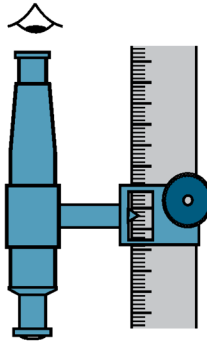

Figure 16.2

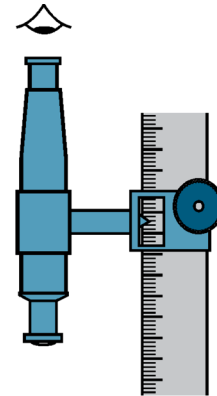

Figure 16.3

The distance from the upper surface of the glass block to the mark 'x' on the paper is the real depth. The distance to the image when the mark is observed normally through the glass block from above is the apparent depth.

If ${}_a n_g$ is the refractive index of glass relative to air,

$${}_a n_g = \frac{\text{real depth}}{\text{apparent depth}}$$

When the travelling microscope is focused on to the mark if x is the reading on the vertical scale, when focused on to the image of the mark the reading is y and when focused on the upper surface of the block the reading is z ,

$$\text{the real depth} = z - x, \quad \text{apparent depth} = z - y$$

$${}_a n_g = \frac{z - x}{z - y}$$

Method

Mark a cross (\times) by ink on the white sheet of paper placed at the base of the travelling microscope. As shown in Figure 16.1 place the microscope directly above the mark \times pointing towards it and focus on the mark. Obtain the reading (x) on the vertical scale. Now place the given glass block on the ink mark. As shown in Figure 16.2 raise the microscope along the scale and focus on the image of the ink mark. Obtain the reading y on the vertical scale. Finally spread the given powder on the upper surface of the glass block vertically above the ink mark. As shown in Figure 16.3 raise the microscope further along the vertical scale and focus on the powder spread on the glass surface. Observe and note down the reading z on the vertical scale. Record all the readings in the Table 16.1 given below.

Readings and calculations

x (cm)	y (cm)	z (cm)	Real depth ($z - x$) (cm)	Apparent depth ($z - y$) (cm)

Calculate the refractive index of glass as explained in the theory.

Conclusion

Conclude the refractive index of glass in accordance with your calculation.

Discussion

Discuss the actions to be taken to increase the accuracy of the experiment.

Note

By placing the glass block with the longer side vertically to increase the real depth, a more accurate value can be obtained from the experiment. The layer of powder on the glass surface should be very thin. If not the reading of z would be erroneous due the thickness of the layer. This experiment could be modified to determine the refractive index of a liquid too.

Determination of the angle of minimum deviation of a prism by observing the variation of deviation of a ray caused by the prism

Materials and apparatus

An equilateral glass prism, a drawing board, drawing pins, a white sheet of paper, four optical pins, a ruler and a protractor.

Theory

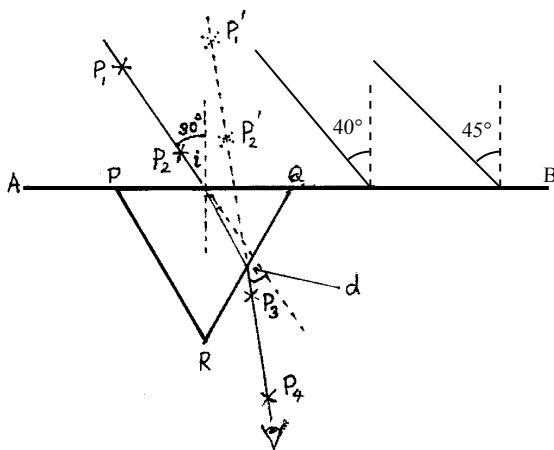

Figure 17.1

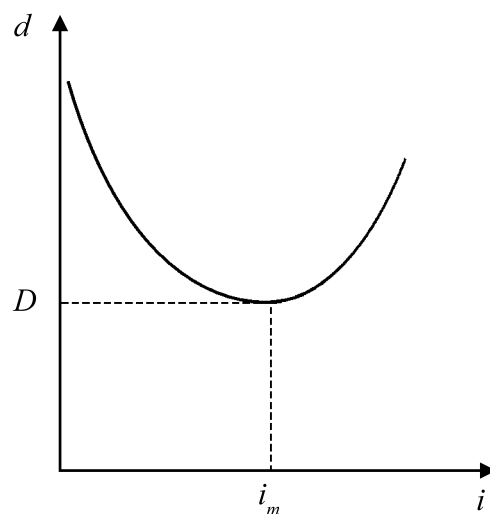

Figure 17.3

When the angle of incidence i is gradually increased from a small value the angle of deviation first decreases, reaches a minimum and then increases. The angle of deviation corresponding to the minimum state is the angle of minimum deviation (D).

Method

Fix the white sheet of paper on the drawing board by drawing pins. Draw a straight line AB close to the middle of the paper along the length of the paper. Mark seven points at suitable gaps on the straight line and at each point draw normals to the line AB. Next draw lines inclined at angles of 30° , 40° , 45° , 50° , 55° , 60° , 70° respectively to each normal. Place the given prism with one edge (PQ) on the line AB with the mid point of the edge coinciding with the point where the first normal is drawn on AB (Figure 17.1). Now fix two pins (P_1 , P_2) vertically on the incident line at a considerable gap from each other. Observe the images of the two pins through the other face QR and fix two other pins (P_3 , P_4) at a considerable gap to be in line with those images (P_1' , P_2'). After marking the edges of the prism on the paper remove it from the paper. Obtain the emergent ray by the line joining the points where the pins P_3 and P_4 were fixed. By extending the incident ray forwards and the emergent ray backwards measure the angle of deviation (d) between the two lines. Repeat the experiment for other angles of incidence in the same way, measure the relevant angles of deviation and record the readings in the Table 17.1.

Readings and calculations

<i>Table 17.1</i>							
angle of incidence (i)	30°	40°	45°	50°	55°	60°	70°
angle of deviation (d)							

Plot d against i and obtain the value of the angle of minimum deviation from the graph.

Conclusion

Conclude the value of the angle of minimum deviation according to the results of the experiment.

Note

Determine the angle of deviation for a few more angles of incidence on either side of the angle of incidence (i_m), relevant to minimum deviation. After obtaining angles of deviation for the range ($i_m \pm 5^\circ$) and marking these values in the graph a more smooth curve can be obtained in and around i_m . This would enable the determination of a more accurate value of the angle of minimum deviation.

By fixing the pins far apart the direction of the emergent ray can be obtained more accurately.

Discuss the actions to be taken to find the angle of deviation d more accurately.

Determination of the refractive index of the material of a prism by the critical angle method

Materials and apparatus

An equilateral prism, a drawing board, drawing pins, a white sheet of paper, a few optical pins, a ruler and a protractor.

Theory

If c is the critical angle on an interface separating two media, then the refractive index of the dense medium relative to the rare medium,

$${}^a n_g = \frac{1}{\sin c}$$

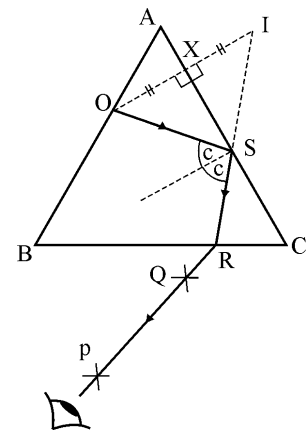

Figure 18.1

Method

Fix the sheet of paper on the drawing board using drawing pins. Place the prism on the paper and mark its edges on the paper in pencil. Fix a pin (O) vertically touching one face (AB) of the prism. Looking through the face BC towards the face AC observe the image of pin O. Move your eye from end C of the face BC towards B until the image of the pin just begins to disappear and at this position, fix two pins (P and Q) vertically to be in line with the disappearing image (and far apart from each other).

Now remove the prism and the pins and make the following constructions on the paper in accordance with the steps given.

- Draw the line OXI normal to AC so that $OX = XI$ and locate the image I on it.
- Join the points where the pins P and Q were fixed and extend the line to meet BC. at R
- Join R and I to intersect AC at S.
- Join OS.
- Measure angle OSR.

Readings and calculations

$$\widehat{OSR} = \dots\dots\dots$$

Since $\widehat{OSR} = 2c$ calculate the value of c and then the value of n_g as shown in the theory.

Conclusion

Conclude from what you obtained in the calculation the value of the refractive index of the material of the prism.

Discussion

Discuss the course of action to be taken to find accurately the critical angle c .

Note

By placing a wet microscope slide on face AC and trapping a water layer it is possible to determine the critical angle for a water / glass interface.

The pin O should be fixed to be in contact with the face AB in order to prevent refraction on face AC and cause errors. By removing the heat of the pin it can be fixed to be in complete contact with the surface of the face AB.

Adjustment of a spectrometer and using it for determination of the refracting angle of a prism

Materials and apparatus

A spectrometer, an equilateral prism, a source of light such as an electric bulb or a lamp flame.

Theory

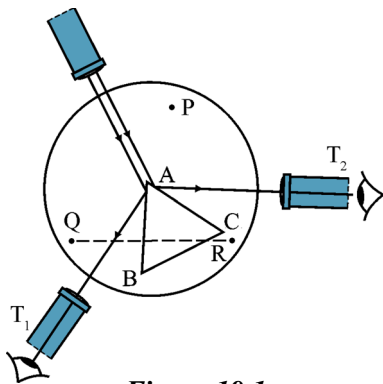

Figure 19.1

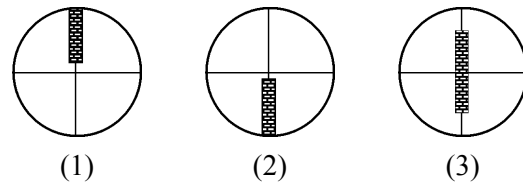

Figure 19.2

As shown in figure 19.1 if the angle between the light rays reflected from the prism face is θ , the difference between the readings corresponding to the positions T_1 and T_2 of the telescope is also θ .

$$\text{The refracting (or prism) angle} = \frac{\theta}{2}$$



Figure 20.1 Spectrometer

Method

Adjustment of the telescope

1. First adjust the gap between the eye piece and the cross-wires until the cross wires are clearly seen
2. Next point the telescope to a distant object and adjust it until a clear image of the object is focussed on the cross wires

Adjustment of the collimator

1. Adjust the slit of the collimator to be narrow and vertical and illuminate it by a source of light.
2. Turn the telescope to be in line with the collimator, observe the image of the slit through the telescope and adjust the collimator until a sharp image of the slit is focussed on the cross wires.

Levelling the prism table

As shown in Figure 19.1 place the prism on the table so that the vertex of the prism is close to the centre of the table and a face (eg AB) is normal to the line joining any two levelling screws. (eg Q and R) Now rotate the prism table with the prism until the light from the collimator falls on both faces of the prism adjacent to the vertex.

Turn the telescope to the position T_1 to receive the light reflected from the face AB of the prism and observe the image of the slit through it. If it appears as seen in the fields of views (1) or (2) of figure 19.2, rotate one of the screws Q and R to make it appear symmetrical as shown in the field of view (3). Next turn the telescope to the position T_2 to receive the light reflected from the face AC. In this position too if the image appears as in a field of view (1) or (2), rotate the screw P only to make it appear symmetrical as in the field of view (3) in Figure 19.2

Repeat the above process until the image of the slit appears symmetrical in both positions T_1 and T_2 without any adjustment of screws. Note that only two levelling screws can be used for the adjustments.

Determination of the refracting angle of the prism

After levelling the prism table and with telescope in position T_1 note down the reading shown on the scale of the spectrometer. Next turn the telescope to the position T_2 and again note down the reading using the vernier scale.

Readings and calculations

<i>Table 19.1</i>			
	Reading at position T ₁	Reading at position T ₂	θ°
Reading of the vernier scale			

Calculate the prism angle A as explained in the theory.

Conclusion

Conclude the value of the prism angle according to your calculations.

Discussion

Discuss any steps to be followed to obtain satisfactory results.

Note

More sensitive and accurate spectrometers are constructed with two vernier scales situated at the ends of a diameter of the circular main scale which is calibrated in half degrees. Readings should be taken from both vernier scales when taking readings. When obtaining the difference between the readings the difference between the positions of each vernier scale should be taken. The mean of the two values of A obtained from the two scales should be considered as the final result. This method of obtaining readings correct any construction errors of the instrument such as the centre of the prism table not coinciding with the centre of the vernier scale.

If in any case the zero of the main scale falls between the positions T₁ and T₂ of the telescope, the difference between the readings should be subtracted from 360° and then divided by 2 to obtain the prism angle.

Determination of the angle of minimum deviation of a prism and the refractive index of the material of the prism using the spectrometer

Materials and apparatus

An adjusted spectrometer, an equilateral prism, a sodium flame or a sodium vapour lamp

Theory

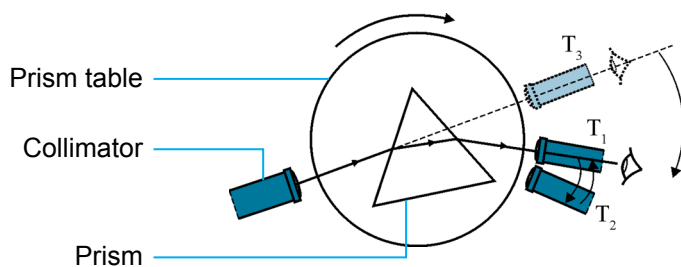

Figure 20.2

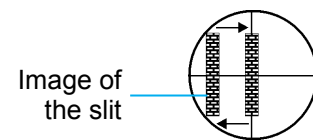

Figure 20.3

If D is the angle of minimum deviation, A the prism angle and n the refractive index of the material of the prism,

$$n = \frac{\sin\left(\frac{D + A}{2}\right)}{\sin\left(\frac{A}{2}\right)}$$

Method

Illuminate the slit of the collimator of an adjusted spectrometer by sodium light. As shown in Figure 20.2 place the prism on the prism table so that the light from the collimator would fall at a small angle of incidence and get refracted through the face of the prism. Turn the telescope to the position T_1 so that the refracted rays could be observed. Now rotate the prism table in the sense of increasing the angle of incidence i gradually. Then as shown in Figure 20.3 it would be seen that the image of the slit would first move in one direction, stop at a certain position and then move back to the initial position.

Turn the telescope until the vertical cross wire in its field of vision coincides with the image of the slit at the position where it stops. At this position T_2 of the telescope, observe and note down the reading on the scale. Then remove the prism from the table and turn the telescope to the position T_3 where it is in line with the collimator. After coinciding the vertical cross wire in the field of view of the telescope with the image of the slit, note down the reading on the scale. Record the readings on the Table 20.1 given below.

Readings and calculations

	Reading in position T_2	Reading in position T_1	Angle of minimum deviation D_m
Reading of the vernier scale			

Use the value obtained for prism angle A in experiment no. 19. Calculate the refractive index n of the material of the prism as explained in the theory.

Conclusion

Conclude the values of the angle of minimum deviation and the refractive index of the prism material according to the results of the experiment.

Note

Follow the methodology used in the note of experiment no. 17 in order to obtain the value of the angle of minimum deviation accurately.

Location of the images formed by a convex lens by the method of no-parallax and hence determination of the focal length of the lens

Materials and apparatus

A convex lens mounted on a stand, two optical pins fixed with stands, a metre ruler and a background screen.

Theory

For a convex lens if u is the object distance, v is the image distance and f the focal length,

$$\frac{1}{v} - \frac{1}{u} = \frac{1}{f}$$

$$\frac{1}{v} = \frac{1}{u} + \frac{1}{f}$$

If the graph is plotted using the new cartesian convention, the intercept of the graph of $1/v$ against $1/u$ will be $1/f$. The focal length of the lens can be calculated accordingly.

(For real images the value of u is + and the value of v is – and hence $1/u$ is + and $1/v$ is –)

If the readings of the experiment are plotted using the sign convention, the graph obtained will be as follows.

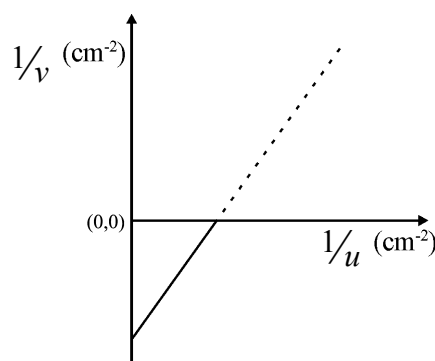

Method

Point the given convex lens to a distant object and obtain its clear image on a screen. Measure the distance between the lens and the screen using the ruler and find the approximate focal length of the lens. Draw a straight line in chalk on the table. Mid way on this line, place the lens mounted on the stand normal to the line. On one side of the lens at a distance little further than the approximate focal length that was found, place the optical pin (O) fixed on the stand on the line drawn so that

the tip of the optical pin is on the optical axis of the lens. Place the background screen on the same side as this object pin but further away from the lens. Place the eye on the opposite side of the lens and observe where an inverted clear image (I) is visible. If not push the object pin further from the lens until the inverted image is visible. (According to Figure 21.1.2, $x \geq$ least distance of distinct vision) Place the eye along the line and get confirmed that the inverted image of O is vertically situated along the line. If it is not, rotate the lens slightly with the stand and adjust it to be correctly normal to the line. Also if the tip of the pin is not seen at the centre of the lens adjust the place of the lens to be vertical. Now place the other optical pin (P) as shown in Figure 21.1.2 along the axis and adjust its tip to be on the principal axis.

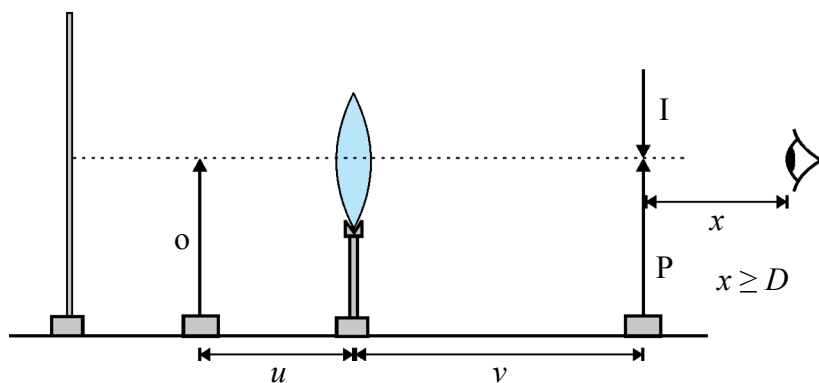

Figure 21.1.2

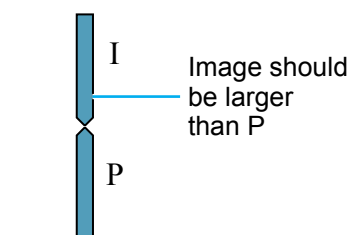

Figure 21.1.3

Adjust P either forwards or backwards until the tip of P coincides with the tip of the image I. In this situation of coincidence (or no-parallax), when the eye of the observer is moved sideways on the axis the tips of I and P should appear to move together without any relative motion.

Now measure the distance u between the lens and the object and the distance v between the lens and the image using the metre ruler. By altering the object distance suitably obtain five more pairs of readings for u and v and record this readings in the Table 21.1.1 (with the appropriate sign according to the new cartesian convention)

Readings and calculations

Table 21.1.1							
u (cm)							
v (cm)							
$\frac{1}{u}$ (cm ⁻¹)							
$\frac{1}{v}$ (cm ⁻¹)							

Plot $1/v$ against $1/u$.

Calculate the focal length of the lens from the intercept of the graph as explained in the theory.

Conclusion

Conclude the value obtained from the above calculation as the focal length of the lens.

Discussion

Discuss any courses of action you could take to minimise the errors and determine the focal length of the lens accurately.

Note

- If the object is placed close to the focal point of the lens the image would be too far from the lens and may not be visible to the eye. (For the image to be visible clearly it should be situated at the least distance of distinct vision from the eye). Hence take care to adjust the object distance suitably.
- The graph is plotted not with values of u but with values of $1/u$. Hence to obtain a good spread of values select values of u so that the gaps between successive values of $1/u$ remain equal.

Eg. Values of u

$$\begin{array}{ccc} 25 \left(\frac{1}{u} = 0.04 \right) & 28 \left(\frac{1}{u} = 0.0357 \right) & 32 \left(\frac{1}{u} = 0.0312 \right) \\ 40 \left(\frac{1}{u} = 0.025 \right) & 50 \left(\frac{1}{u} = 0.02 \right) & 65 \left(\frac{1}{u} = 0.0154 \right) \end{array}$$

- Since the real images of a convex lens can be interchanged with respective objects (conjugate points) any pair of values of u and v can be interchanged and taken as another pair of values.
- This experiment details only with real objects and real images. But if required, the experiment can be performed as real objects - virtual images or virtual objects - real images (according to new cartesian sign convention for real objects - virtual images it will be $+u$ and $+v$ while for virtual object - real images it $-u$ and $-v$).

The graph can be drawn for all these situations and it will occupy quadrants 1, 3 and 4. It will be one straight line for all three situations and the focal length can be found from the intercept of any graph.

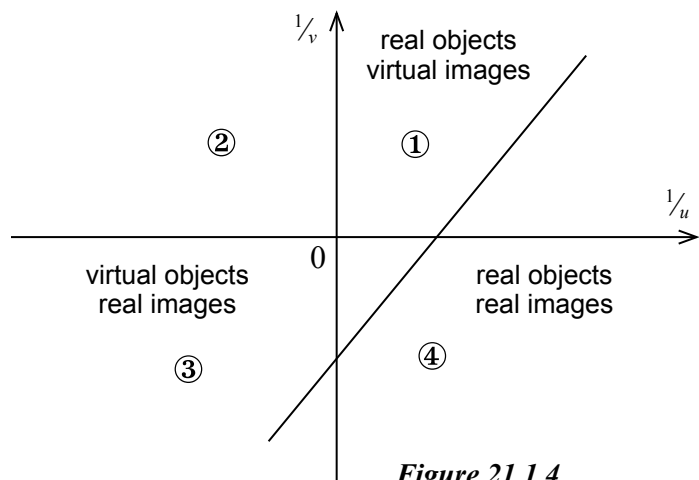

Figure 21.1.4

Alternative methods of calculating focal length

For real objects and real images,

- (i) when the sign convention is applied to all u , v and f ,

$$-\frac{1}{v} - \frac{1}{u} = -\frac{1}{f}$$

$$\frac{1}{|v|} = -\frac{1}{|u|} + \frac{1}{|f|}$$

when $\frac{1}{|u|}$ is plotted against $\frac{1}{|v|}$,

the intercept of the graph $c = \frac{1}{|f|}$

$$|f| = \frac{1}{c}$$

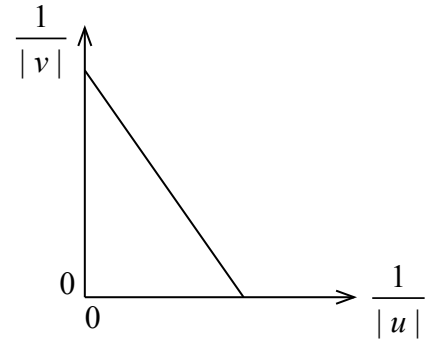

- (ii) when the sign convention is applied to all u , v and f ,

$$\frac{1}{-v} - \frac{1}{u} = \frac{1}{-f}$$

Hence
$$\frac{1}{|v|} + \frac{1}{|u|} = \frac{1}{|f|}$$

Multiplying by $|u v|$

$$|u| + |v| = \left| \frac{u v}{f} \right|$$

$$|u v| = |f| (|u + v|)$$

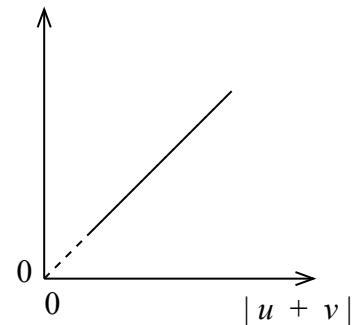

When $|u v|$ is plotted against $|u + v|$, the gradient gives the value of $|f|$.

From the readings it can be verified that for real objects and real images $|u| + |v| \geq 4|f|$.

Location of the images formed by a concave lens by the method of no-parallax and hence determination of the focal length of the lens

Materials and apparatus

A concave lens mounted on a stand, 2 optical pins, a plane mirror strip, a metre ruler and a background screen.

Theory

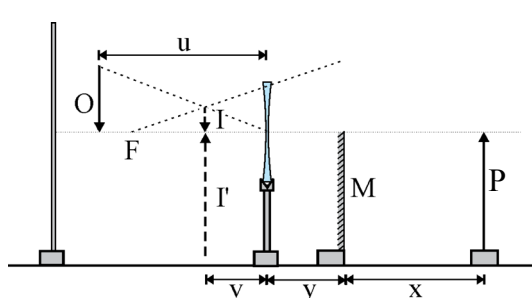

Figure 21.2.1

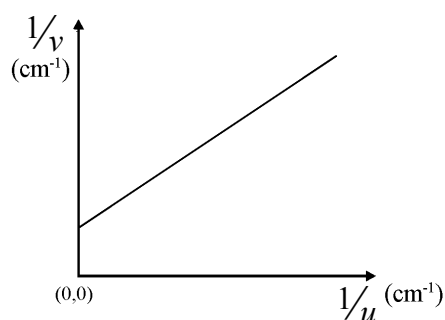

Figure 21.2.1

For a concave lens, if u is the object distance, v is the image distance and f is the focal length, According to the common formula,

$$\frac{1}{v} - \frac{1}{u} = \frac{1}{f}$$

$$\frac{1}{v} = \frac{1}{u} + \frac{1}{f}$$

Applying the sign convention (new cartesian) and plotting $1/v$ against $1/u$ the graph would give an intercept $c = 1/f$.

The value of f can be hence calculated.

Method

Draw a straight line on the table using chalk and towards the middle of the line place the stand carrying the lens normally to the line so that the plane of the lens too is normal to the line. On one side of the lens place a pin mounted on a stand so that the tip of the pin lies on the principal axis of the lens as shown in the Figure 21.2.1. Place the background screen at a distance from that pin which is considered as the object (O). Now place the eye above the line on the table and on the side opposite to that where the object is and observe whether the upright diminished image and the object are seen in line along the central region of the lens. If not adjust the lens with the stand by rotating it slightly (until the plane of the lens is normal to the principal axis) to bring the image to the optical axis of the lens.

Now place the plane mirror strip (M) as shown in the figure on the side opposite to that of the object and below the principal axis of the lens covering one half of the lens. Next fix the second optical pin on a stand and place it on the line drawn on the table so that the tip of the pin touches the principal axis of the lens. Place the eye as shown in the figure and vary the distance between the mirror and the pin P until the tip of the small upright image I seen through the lens is seen to coincide with the tip of the image I' formed behind the mirror. Measure the object distance u , the distance between the lens and the mirror y and the distance between the mirror and the pin P, x . Vary u arbitrarily keeping the value of y constant and measure the distance x for five more situations of coincidence and record the results in the table given as below.

Readings and calculations

<i>Table 21.2.1</i>	
u (cm)	
$\frac{1}{u}$ (cm)	
x (cm)	
$v = x - y$ (cm)	
$\frac{1}{v}$ (cm ⁻¹)	

Plot $1/v$ against $1/u$.

Calculate the focal length of the lens from the intercept of the graph using the theory. (Find the gradient of the graph (m), obtain coordinates x, y of a suitable point on the graph. Substituting the values of x, y and m in the equation $y = mx + c$ and calculate c)

Conclusion

Conclude the value obtained from the above calculations as the focal length of the lens.

Discussion

Discuss the courses of action to be taken to minimise errors and find the focal length of the lens more accurately.

Note

Read the note on the experiment 21.1. Those suggestions can be used to select the values of u . Since images can be obtained between the optical centre and the focus for all positions of real objects, select the values of u to spread widely.

Determination of the atmospheric pressure using the Quill tube

Materials and apparatus

A Quill tube (a thin glass tube having a column of dry air trapped inside by a thread of mercury), a metre ruler and a clamp stand.

Theory

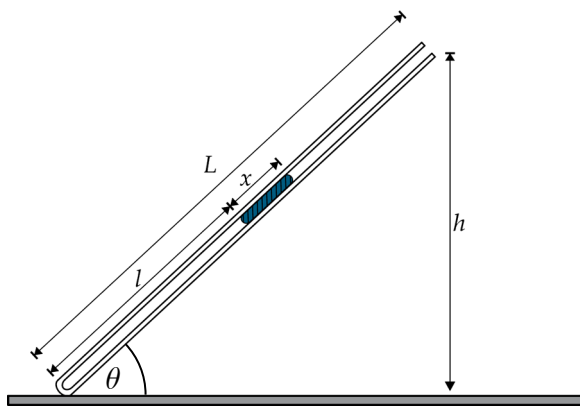

Figure 22.1

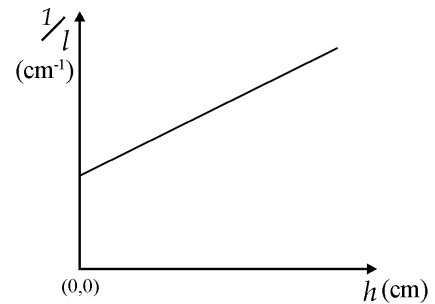

Figure 22.2

- h – vertical height from the table to the top end of the tube
- l – length of air column
- L – length of the tube
- A – Internal area of cross-section of the tube
- x – length of the mercury thread
- ρ – density of mercury
- H – atmospheric pressure (cm Hg)

According to Boyle's law : $p = \frac{k}{v}$, $(H + x \sin \theta) \rho g = \frac{k}{Al}$

$$\left(H + \frac{xh}{L}\right) \rho g = \frac{k}{Al} \quad , \quad \frac{1}{l} = \left(\frac{Ax\rho g}{kL}\right)h + \frac{AH\rho g}{k}$$

Gradient of the graph $\frac{1}{l}$ against $h = \frac{Ax\rho g}{kL}$ Intercept = $\frac{AH\rho g}{k}$

$$H = \frac{\text{Intercept}}{\text{Gradient}} \times \frac{x}{L}$$

Method

Attach the tube to the stand as shown in the Figure 22.1 with its closed end on the table and inclined to the horizontal. Measure the height h from the table to the top end of the tube and the length l of the air column and note down these values. Change the inclination of the tube by adjusting the stand and obtain six pairs of values of h and l . Enter these values in the following Table 22.1. Also measure and note down the length x of the mercury thread and the length L of the tube.

Readings and calculations

h (cm)									
l (cm)									
$1/l$ (cm ⁻¹)									

Length of the mercury thread (x) = cm

Length of the tube (L) = cm

Plot $1/l$ against h , calculate the gradient of the graph, obtain the intercept and calculate the atmospheric pressure H as explained in the theory.

Conclusion

Conclude the value of H as obtained from the results of the experiment.

Discussion

Obtain the atmospheric pressure from a standard barometer and calculate the percentage error of your experimental value.

Note

To prepare the Quill tube take a narrow glass tube of about one metre in length, internal diameter about 2 mm and open at both ends. Insert into it a mercury thread about 10 cm long. Place the tube horizontally and arrange the thread of mercury to reach the middle of the tube. Now hold one end of the tube to a bunsen flame and seal the end while rotating the tube. Place the tube on the metre ruler so that the closed end of the tube coincide with the zero mark of the ruler and attach the tube to the ruler using rubber bands.

Readings can be obtained for negative values of h too by keeping the tube inverted with open end pointing downwards.

If a straight line graph is obtained as expected from the results of the experiment, the relationship used (Boyle's law) to derive the equation gets verified too.

Verification of the relationship between the volume and the temperature of a gas at constant pressure

Materials and apparatus

Narrow uniform glass tube with thin walls closed at one end having a column of dry air trapped by an index of mercury at the closed end, a (0 - 100) °C thermometer, a tall beaker of water, a stirrer, a tripod, a wire gauze a bunsen burner, a clamp stand, a few rubber bands and a scale calibrated in mm.

Theory

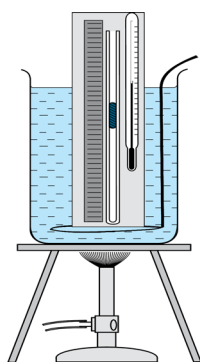

Figure 23.1

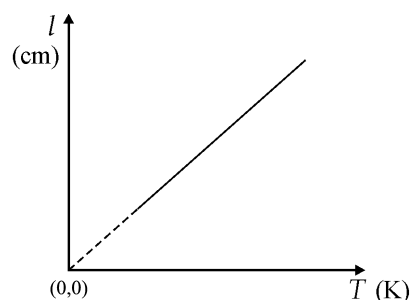

Figure 23.2

According to the Figure 23.1, if the volume of the air trapped in the tube is V and the Kelvin temperature of the gas is T , then according to Charles' law,

$$V \propto T \quad \text{of a fixed mass of a gas at constant pressure}$$

$$\therefore V = KT$$

If the length of the air column is l and the area of internal cross-section of the tube is A ,

$$V = lA$$

$$\therefore lA = KT$$

$$l = \frac{K}{A} T$$

If the graph of l plotted against T passes through the origin as a straight line, the relationship between the volume of the gas and its temperature is verified.

Method

Attach the tube to the scale so that the closed end of the tube coincides with the zero of the scale and fix the thermometer placing its bulb close to the middle of the air column. Set up the apparatus as shown in the Figure 23.1 and note down the reading of the thermometer and the length of the air column. Heat the water in the beaker while being stirred. When the temperature has increased by

about 10° C remove the burner, stir the water and maintaining a constant reading of the thermometer note down the reading of the thermometer and the length of the air column again when the mercury index becomes still. Continue the heating of the water in the beaker while being stirred and obtain six pairs of readings in this manner at every 10° C rise of temperature. Enter all the readings in the table 23.1.

Readings and calculations

Table 23.1							
Temperature θ (°C)							
Temperature T (K)							
Length of air column l (cm)							

Plot l against T .

Conclusion

Conclude the relationship between the volume and the temperature of a gas at constant pressure as illustrated by the graph.

Discussion

Discuss how the courses of action taken to increase the accuracy of the results have influenced the experiment.

Note

It is more suitable to note down the length of the air column on two occasions, once when the temperature is rising and next when the temperature is falling. This would minimize the error due to the sticking of the mercury index to the wall of the tube.

By bending the tube as shown in Figure 23.3 to increase the length of the air column in the narrow uniform tube or by connecting a small glass bulb to the end of the tube the sensitivity of the apparatus can be increased and this would enable to obtain a good spread between the readings.

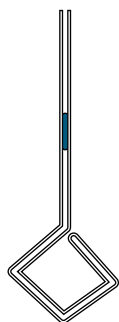

Figure 23.3

If V is the volume of the air enclosed in the bent portion of the tube and A the area of internal cross section of the tube,

$$A l + V = K T$$

$$l = \left(\frac{K}{A} \right) T - \frac{V}{A}$$

To verify the relationship between the pressure and the absolute temperature of a gas at constant volume

Materials and apparatus

A constant pressure gas apparatus with a pressure gauge, a (0 - 100 °C) thermometer, a beaker of water, a Bunsen burner, a tripod, a wire gauze, a stand and a stirrer.

Theory

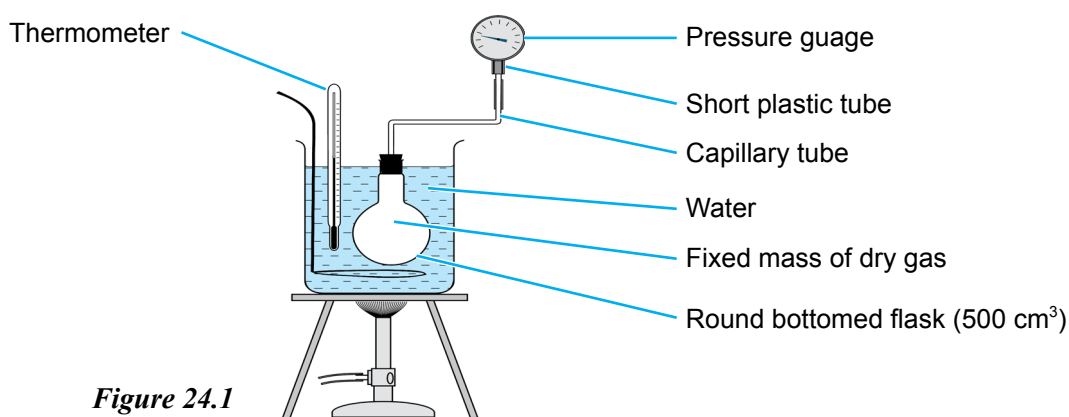

Figure 24.1

As shown in Figure 24.1 if p is the pressure of the air enclosed in the bulb and T the absolute temperature of the gas, then according to the law of pressures the relationship between p and T of a fixed mass of a gas at constant volume is,

$$p \propto T$$

When p is plotted against T the graph would be as follows.

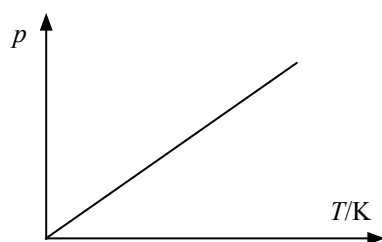

Figure 24.2

If the temperature is measured in °C the graph would be as follows

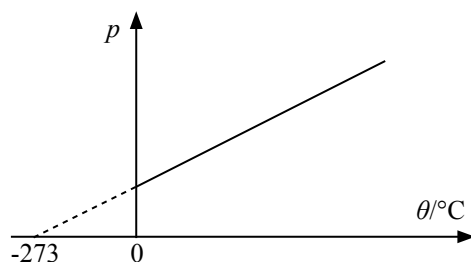

Figure 24.3

Method

As shown in Figure 24.1 place the bulb of the constant volume apparatus, the thermometer and the stirrer in the water in the beaker. Heat the water in the beaker while stirring and when the temperature has risen by about 10 °C remove the burner and when the temperature becomes still note down the temperature reading and the pressure gauge reading. Continue to heat the water in the beaker and at every rise of 10 °C of temperature take relevant readings six times and enter in the Table 24.1.

Readings and calculations

Reading of the thermometer θ (°C)						
Absolute temperature T (K)						
Reading of the pressure gauge p (N m ⁻²)						

Plot pressure p against absolute temperature T .

Conclusion

As stated in the theory, according to the graph the relationship between the pressure and the temperature of a gas at constant volume is verified.

Note

The temperature of the water in the heater should be raised very slowly and the water should be continuously stirred. Since the temperature of the air in the tube connecting the bulb and the gauge and the temperature of the air in bulb do not exist at the same value, the resulting error can be minimised by using a bulb with a large volume and a capillary tube as the connecting tube.

Determination of the specific heat capacity of a solid substance by the method of mixtures

Materials and apparatus

A calorimeter, a boiling tube, a quantity of lead shots, a (0 - 100) °C thermometer, a water heater, a tripod, a wire gauze, a three beam balance, sufficient water, a stirrer and also a (0 - 50) °C thermometer.

Theory

When a warm substance and a cold substance are mixed, if no losses of heat to the surroundings take place, then the heat lost by the warm substance is equal to the heat gained by the cold substance. In the experiment referred to above if,

- | | | | |
|--------|---|---|------------|
| 1. | Mass of empty calorimeter and stirrer | = | m_1 |
| 2. | Mass of calorimeter with water | = | m_2 |
| 3. | Initial temperature of the water | = | θ_1 |
| 4. | Temperature of the heated lead shots | = | θ_2 |
| 5. | Maximum temperature of the mixture | = | θ_3 |
| 6. | Mass of the calorimeter with the mixture | = | m_3 |
| 7. | Specific heat capacity of the calorimeter metal | = | c_1 |
| 8. | Specific heat capacity of water | = | c_2 |
| and 9. | Specific heat capacity of lead shots | = | c_3 , |

Then according to the above principle,

$$\text{Heat lost by lead shots} = \text{Heat gained by water} + \text{Heat gained by calorimeter}$$

$$(m_3 - m_2) c_3 (\theta_2 - \theta_3) = [m_1 c_1 + (m_2 - m_1) c_2] (\theta_3 - \theta_1)$$

Method

Measure the mass (m_1) of the calorimeter with the stirrer. Fill up to about centimeter below the top of the calorimeter with water at room temperature and measure the mass (m_2) again. Put a sufficient amount of the substance (lead shots) of which the specific heat capacity (c_3) is to be found into the tube and heat it with the help of the water heater. After heating till the water boils, measure and record the temperature (θ_2) of the lead shots when it becomes constant. Now put the heated lead shots instantly into the water in the calorimeter, stir the mixture well and note down the maximum temperature (θ_3) of the mixture. Use the (0 - 50) °C thermometer for this measurement.

Finally measure the calorimeter with its contents and note down the mass (m_3). Use the triple beam balance for all the weighings.

Readings and calculations

m_1 =
 m_2 =
 θ_1 =
 θ_2 =
 θ_3 =
 m_3 =

Using the standard values for the specific heat capacities of the calorimeter metal and water, calculate the specific heat capacity of lead shots as explained in the theory.

Conclusion

Conclude the value obtained from the calculation as the specific heat capacity of lead shots.

Discussion

Refer a standard data book and obtain the standard value of the specific heat capacity of lead shots and calculate the percentage error of the value you obtained from the experiment.

Discuss the sources of error such as loss of heat and the remedies to minimize these errors.

Note

- Take the calorimeter with its external covering to the place where the lead shots are being heated. If not place a heat insulated obstacle between the water heater and the calorimeter.
- When the lead shots are being transferred to the calorimeter, care should be taken to prevent splashing out of the water in it and to observe the thermometer reading very carefully. Since lead is a good conductor the mixture reaches the maximum temperature very soon.
- This method can be used to determine the specific heat capacity of a liquid by using the liquid in place of the water and a substance of known specific capacity as the solid substance.
- A pilot experiment should be done to decide the amount of lead shots to be used to mix in order that the temperature of the mixture would rise by about 10 °C.
- Method of compensation can be used as a remedy for the loss of heat. The initial temperature of the calorimeter with water is first cooled by about 5 °C before mixing the heated substance. The heated substance is then added to the water and mixed well so that the temperature of the mixture rises by 5 °C above the initial temperature. The heat gained by the mixture during the 5 °C below the initial temperature is expected to compensate with the heat lost by the mixture during the 5 °C above the initial temperature.
- In the above process care should be taken to have the initial temperature of water a few degrees above the dew point.

Determination of the specific heat capacity of a liquid by the method of cooling

Materials and apparatus

A calorimeter having a polished outer surface and containing a lid and a stirrer, a (0 - 100) °C thermometer, an electric fan, a stop clock, a triple beam balance, sufficient water and the liquid.

Theory

Considering two warm bodies cooling in a continuous stream of air, if the nature and areas of their surfaces and the excess temperatures of the bodies over that of the surroundings are all identical, then their mean rates of loss of heat will be equal.

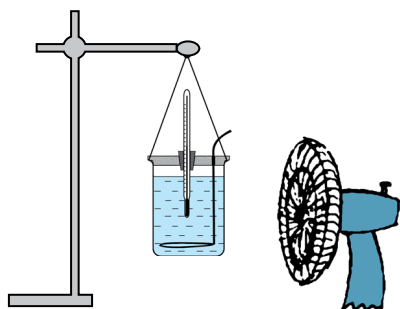

Figure 26.1

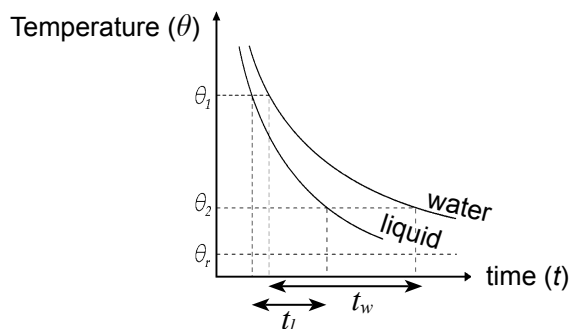

Figure 26.2

Consider an experiment in which using a single calorimeter, equal volumes of two warm liquids are allowed to cool under identical conditions.

In this experiment let,

Mass of empty calorimeter with stirrer	=	m_1
Mass of calorimeter with water	=	m_2
Mass of calorimeter with an equal volume of liquid	=	m_3
Time taken by calorimeter with water to cool in the range $\theta_1 - \theta_2$	=	t_w
Time taken by calorimeter with liquid to cool in the range $\theta_1 - \theta_2$	=	t_l
Specific heat capacity of calorimeter metal	=	c
Specific heat capacity of water	=	c_w
Specific heat capacity of liquid	=	c_l

$$\frac{[m_1 c + (m_2 - m_1) c_w] (\theta_1 - \theta_2)}{t_w} = \frac{[m_1 c + (m_3 - m_1) c_l] (\theta_1 - \theta_2)}{t_l}$$

c_l can be calculated by solving the above equation using standard values for c and c_w .

Method

Measure the mass (m_1) of the empty calorimeter with the stirrer. Fill up to about one centimetre from the top of the calorimeter with water heated to about 70 °C, close with the lid and suspend from the stand as shown in the Figure 26.1. Allow the calorimeter to cool by the continuous blow of air from the electric fan placed near the calorimeter. While stirring the water continuously observe and note down its temperature at 30 s intervals till the temperature falls to about 40 °C. Finally measure the mass (m_2) of the calorimeter and note it down. Now remove the water from the calorimeter, wipe it well, fill it with an equal volume of heated liquid and repeat the experiment in the same manner. After recording the readings measure the mass (m_3) of the calorimeter with the liquid. Enter readings of both experiments in the Table 26.1.

Readings and calculations

Time (minutes)	0	0.5	1.0	2.0	2.5	3.0
Temperature of water (°C)						
Temperature of liquid (°C)						

Mass of the empty calorimeter with stirrer $m_1 =$

Mass of the calorimeter with water $m_2 =$

Mass of the calorimeter with liquid $m_3 =$

Time taken by water to cool from θ_1 to θ_2 $t_w =$

Time taken by liquid to cool from θ_1 to θ_2 $t_l =$

Draw smoothly the curves of temperature against time on the same coordinate axes for both water and liquid. From these temperature - time curves obtain the times taken by the liquid and water separately to cool within the same temperature interval. Using standard values for c_w and c calculate the specific heat capacity (c_l) of the liquid as explained in the theory.

Conclusion

Conclude the value obtained in the calculation as the specific heat capacity of the liquid.

Discussion

Compare the value obtained in the experiment with the standard value of the specific heat capacity of the liquid. Forward your ideas and suggestions to minimize the experiment errors.

Note

This experiment can also be used for low excess temperatures such as those in the range 20 °C - 30 °C and no continuous flow of air is required here. However an environment of still air has to be maintained around the calorimeter. In the calculation it is more accurate to find the rate of fall of temperature relevant to a specific excess temperature as shown in Figure 26.3 than finding the mean rate of fall of temperature over a temperature range.

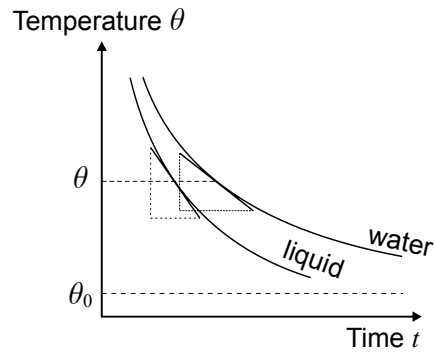

Figure 26.3

As shown above, at temperature θ a horizontal line is drawn. At the points of intersection of the line with the curves tangents to the curves should be constructed using a plane mirror. If the gradients of the tangents are α_l and α_w ,

$$\left(\frac{d\theta}{dt} \right)_l = \tan \alpha_l$$

$$\left(\frac{d\theta}{dt} \right)_w = \tan \alpha_w$$

$$\left(\frac{dQ}{dt} \right)_w = [m_1 c + (m_2 - m_1) c_w] \left(\frac{d\theta}{dt} \right)_w$$

$$\left(\frac{dQ}{dt} \right)_l = [m_1 c + (m_3 - m_1) c_l] \left(\frac{d\theta}{dt} \right)_l$$

$$\left(\frac{dQ}{dt} \right)_w = \left(\frac{dQ}{dt} \right)_l$$

$$\therefore [m_1 c + (m_2 - m_1) c_w] \left(\frac{d\theta}{dt} \right)_w = [m_1 c + (m_3 - m_1) c_l] \left(\frac{d\theta}{dt} \right)_l$$

The value of c_l can be calculated from the above equation.

Determination of specific latent heat of fusion of ice by the method of mixtures

Materials and apparatus

A calorimeter, a stirrer, a thermometer, water, a sufficient quantity of ice, filter papers, a four beam balance, chemical balance and a box of weights

Theory

In the experiment above, let,

The mass of an empty calorimeter with a stirrer	=	m_1
Mass of the calorimeter with a quantity of water	=	m_2
The initial temperature of the water	=	θ_1
Minimum temperature of the mixture when mixed with ice	=	θ_2
Mass of the calorimeter with final contents	=	m_3
Specific heat capacity of water	=	c_w
Specific heat capacity of calorimeter metal	=	c_l
Specific latent heat of fusion of ice	=	L

Then since $0^\circ\text{C} < \theta_2 < \theta_1$,

assuming that no heat was absorbed from the surroundings, during mixing

Heat gained by ice = Heat lost by water and calorimeter (with stirrer)

$$(m_3 - m_2)L + (m_3 - m_2)c_w\theta_2 = [m_1c_l + (m_2 - m_1)c_w](\theta_1 - \theta_2)$$

Method

Measure the mass (m_1) of the calorimeter with the stirrer. Fill about two thirds of the calorimeter with water at room temperature and measure its mass (m_2) again. Measure also the temperature (θ_1) of the water. Wipe out water from small pieces of ice using filter paper and put those one by one into the water in the calorimeter while stirring, taking care to insert one piece after the previous one has dissolved. Use a square-net stirrer to prevent the ice from floating in water.

When the temperature of the water has fallen sufficiently (by about 5°C) stop adding ice, stir the mixture well and record the lowest temperature of the mixture (θ_2). Finally measure the mass of the calorimeter with its contents again (m_3).

Readings and calculations

m_1	=
m_2	=
θ_1	=
θ_2	=
m_3	=
$m_2 - m_1$	=
$m_3 - m_1$	=

Substitute values of m_1 , m_2 , θ_1 , θ_2 and standard values for c_i and c_w in the expression given in the theory and calculate the value of L .

Conclusion

Conclude the value obtained from the calculation as the specific latent heat of fusion of ice.

Discussion

Compare the value of specific latent of fusion of ice you obtained from the experiment with its standard value you would obtain from a data book and calculate its percentage error.

Note

It is advisable to determine the dew point approximately before mixing ice. Then by preventing the final temperature of the mixture going below the dew point, the error caused by the dew depositing on the calorimeter surface can be minimized.

When the temperature of the calorimeter begins to fall below room temperature with the mixing of ice, it begins to gain heat from the surroundings. This can be minimized by lagging the calorimeter with heat absorbing materials.

Or else the compensation method used in the method of mixtures can be used. Heat the calorimeter with water by about $5\text{ }^\circ\text{C}$ above room temperature. Considering this temperature as the initial temperature θ_1 , mix pieces of ice until the temperature of the water falls below the room temperature by the same number of degrees ($5\text{ }^\circ\text{C}$). Assuming that the heat lost by the system during the $5\text{ }^\circ\text{C}$ above room temperature compensated with the heat gained by the system during the $5\text{ }^\circ\text{C}$ below room temperature, the error due to heat gained from surround can be considered to have minimized.

Determination of the specific latent heat of vapourization of water by the method of mixtures

Materials and apparatus

A calorimeter, a stirrer, a thermometer, a steam generator, a steam trap, a four beam / chemical balance, an insulating sheet (rigifoam / asbestos), a bunsen burner, a tripod, a wire mesh and a (0 - 50) °C thermo meter.

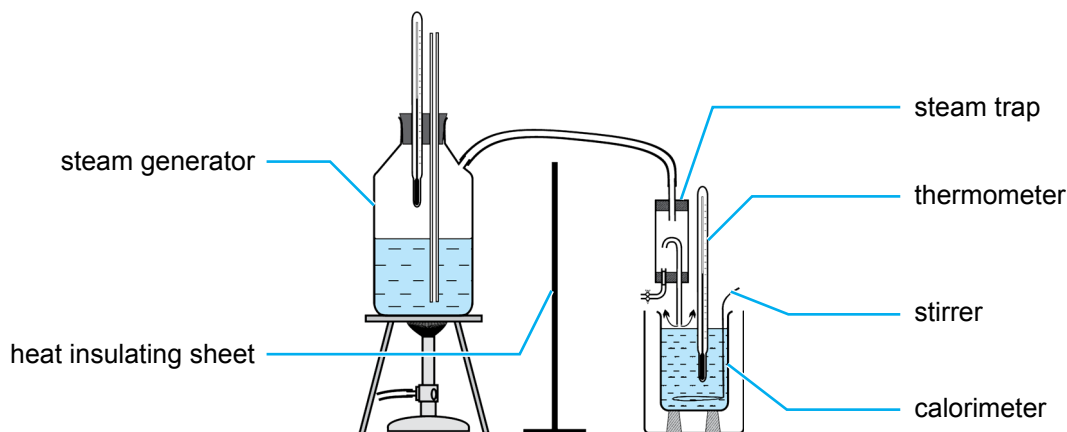

Figure 28.1

Theory

In the experiment referred to above, let,

- | | | |
|---|---|------------|
| 1. The mass of the empty calorimeter with the stirrer | = | m_1 |
| 2. The mass of the calorimeter with water | = | m_2 |
| 3. The initial temperature of the water | = | θ_1 |
| 4. Maximum temperature of the water after mixing with steam | = | θ_2 |
| 5. Mass of the calorimeter with the mixture | = | m_3 |
| 6. Specific heat capacity of the calorimeter metal | = | c_l |
| 7. Specific heat capacity of water | = | c_w |
| 8. Specific latent heat of vaporization of water | = | L |

then, assuming no loss of heat to the surroundings,

Heat lost by steam = Heat gained by calorimeter and water

$$(m_3 - m_2)L + (m_3 - m_2)c_w(100 - \theta_2) = [m_1c_l + (m_2 - m_1)c_w](\theta_2 - \theta_1)$$

Method

Measure the mass (m_1) of the calorimeter with the stirrer. Fill about two thirds of the calorimeter with water at room temperature and measure the mass (m_2) again and the temperature (θ_1) of the water. Arrange the steam generator to supply a continuous stream of steam, obtain dry steam after passing through the trap and allow the steam to strike the surface of water in the calorimeter as

shown in Figure 28.1. Stir the mixture well and after its temperature has risen by about 10 °C stop mixing steam. After stirring to reach the maximum temperature note down the temperature (θ_2) and finally measure the mass (m_3) of the calorimeter with its contents.

Readings and calculations

m_1 =

m_2 =

m_3 =

θ_1 =

θ_2 =

Calculate the value (L) of the specific latent heat of vaporization of water as explained in the theory.

Conclusion

Conclude the value of L you obtain as the specific latent heat of vaporization of water.

Discussion

Compare the value of the specific latent heat of vaporization of water you obtained in the calculation with its standard value you would obtain from a data book. Hence calculate its percentage error. Also discuss the necessity of using the steam trap and the insulating screen. In addition discuss the reasons for inserting the long open tube into the water in the steam generator and also not immersing the tube of the steam trap in the water in the calorimeter.

Note

One way to minimize the error due to heat loss is to use a polished calorimeter, cover it with heat insulating materials and placing it in another vessel. However the compensation method is the more accurate method. In this, the experiment has to be done under constant environmental conditions and no measures are required to prevent heat losses.

In the compensation method, the initial temperature has to be lowered to by about 5 °C below room temperature and mixing of steam is commenced with stirring. When the temperature of the mixture rises by the same number of degrees (5 °C) above room temperature, the mixing of a steam has to be controlled to keep this temperature. Then the heat lost to the surrounding during the 5 °C above room temperature can be expected to compensate with the heat gained from the surroundings during the 5 °C below room temperature. The lowest temperature which is considered as the initial temperature in this process should be a little above the dew point.

Since the amount of steam that collects in this experiment is small, care has to be taken regarding accuracy in measuring the mass.

The compensation method is often referred to as a method of minimising heat losses. But here heat loss is allowed and is compensated by heat gain. Hence the error due to heat loss is minimized.

Determination of relative humidity of air using a polished calorimeter

Materials and apparatus

Two calorimeters with polished outer surfaces, a sufficient amount of ice chips, a stirrer, two (0 - 50) °C thermometers, a sheet of glass and two stands.

Theory

$$\text{Relative humidity} = \frac{\text{saturated vapour pressure of water at dew point } (p_0)}{\text{saturated vapour pressure of water at room temperature } (p)} \times 100\%$$

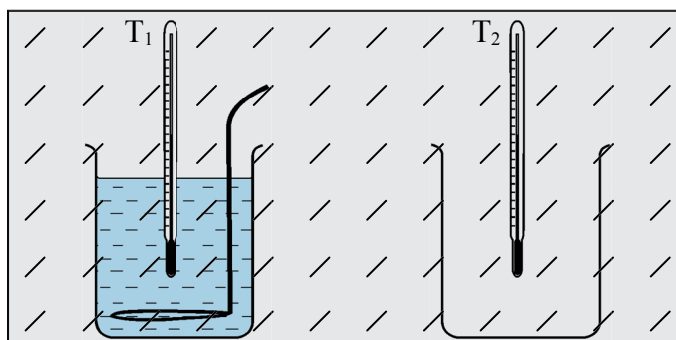

Figure 29.1

Method

Wipe out well the outer surface of the calorimeters and fill about a half of one calorimeter with water. Fix the two thermometers T_1 and T_2 as shown in Figure 29.1. Also fix the sheet of glass in front of the calorimeters to prevent your exhaled air reaching the calorimeters. Insert ice chips into water in the calorimeter one after the other while stirring each one after the previous one has dissolved.

Observe the beginning of the tarnishing of the calorimeter surface due to depositing of dew by comparing the surface with the outer surface of the other calorimeter. In the situation where dew begins to deposit, observe and note down the reading (θ_1) of the thermometer T_1 inserted into the calorimeter containing water.

Now stop adding ice and continue stirring to allow the temperature of the water to rise when the shine of the calorimeter begins to reappear indicating the vanishing of dew, observe the reading (θ_2) of the same thermometer T_1 and note it down. Finally observe and record the room temperature θ_R from the thermometer T_2 .

Readings and calculations

Temperature at which dew deposits $\theta_1 = \dots\dots\dots$

Temperature at which dew vanishes $\theta_2 = \dots\dots\dots$

Room temperature $\theta_R = \dots\dots\dots$

Calculate the mean $\left(\frac{\theta_1 + \theta_2}{2} \right)$ of the two temperatures and consider it as the dew point.

Using a table giving standard values of saturated vapour pressure, obtain its values at the dew point and at the room temperature (p_0 and p). Calculate the relative humidity using the expression given in the theory.

Conclusion

Conclude the value obtained from the above calculation as the relative humidity.

Discussion

Discuss the necessity to use small ice chips for the experiment. Discuss the difficulties you would face in measuring temperatures θ_1 and θ_2 if large pieces of ice are used.

Note

In selecting the glass sheet to prevent exhale striking the calorimeter, take care to decide on its dimensions so that it would not obstruct stirring but would have the size sufficient for the purpose it is used for.

Determination of the thermal conductivity of a metal by Searle's method

Materials and apparatus

Searle's apparatus for determination of thermal conductivity, two (0 - 110) °C thermometers, two (0 - 50) °C thermometers, a steam generator, a constant pressure apparatus, vernier caliper, a stop clock, a 100 ml beaker and a triple beam balance

Theory

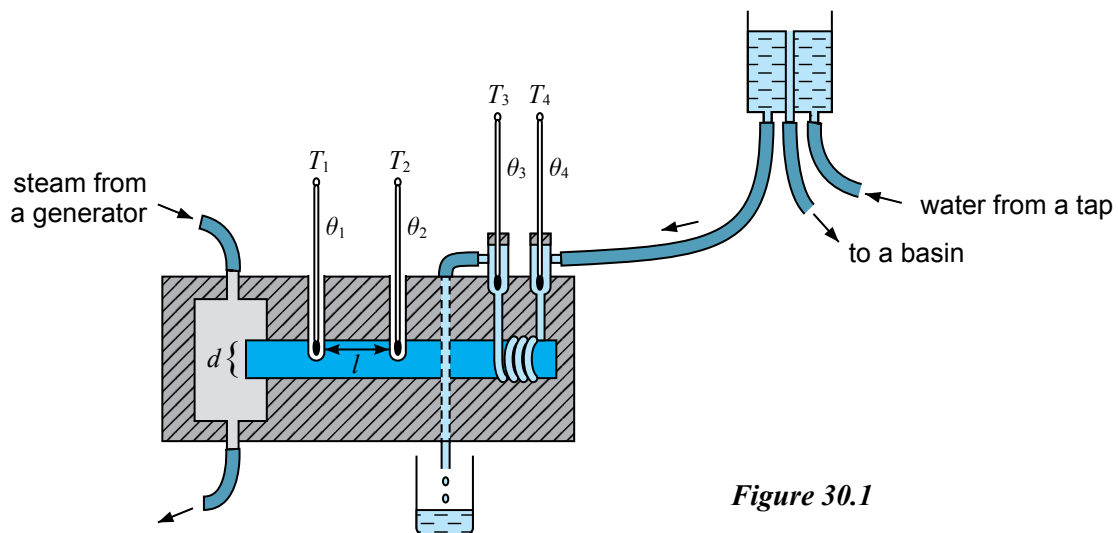

Figure 30.1

As shown in the above Figure 30.1, let,

the mean diameter of the bar	=	d
distance between thermometer T_1 and T_2	=	l
readings of the thermometers T_1, T_2, T_3, T_4 in the steady state	=	$\theta_1, \theta_2, \theta_3, \theta_4$
mass of water collected in the beaker	=	m_w
time during which water is collected	=	t
specific heat capacity of water	=	c_w
thermal conductivity of the material of the bar	=	k

$$\text{Then } \frac{dQ}{dt} = kA \cdot \frac{d\theta}{dt}$$

$$\frac{m_w c_w (\theta_3 - \theta_4)}{t} = k \pi \left(\frac{d}{2} \right)^2 \frac{(\theta_1 - \theta_2)}{l}$$

Method

First open the wooden box and using the vernier calliper measure two diameters (d_1 , d_2) of the bar in two directions normal to each other to get the mean diameter. Also using the calliper measure distances (l_1) from inside and (l_2) from outside between the thermometer T_1 and T_2 (0 - 110 °C) with the help of the outer jaws and the inner jaws of the calliper. Close the box now to provide heat insulation.

Insert the thermometers T_1 and T_2 into the respective holes containing mercury to ensure good thermal contact. Use the upper inlet of the steam chamber to admit steam so that the chamber will be completely filled with steam throughout the experiment. Connect the water outlet of the constant pressure apparatus to the T_4 thermometer chamber so that the incoming stream of water would oppose and meet directly the heat conducted along the bar. Note down the readings of the four thermometers at five minute time intervals. When all these four readings become constant indicating steady state record the four readings θ_1 , θ_2 , θ_3 , θ_4 . If the difference between the readings of T_2 and T_4 is not sufficient, adjust the height of the water pressure head to obtain a sufficient difference.

Finally collect water from the T_3 outlet into an initially weighed (m_0) beaker for a time (t) which is measured by a stop clock. Collect about 500 ml of water and measure the mass of the beaker with the water (m_1).

Record the readings in the following tables.

Readings and calculations

Table 30.1			
	d_1 (cm)	d_2 (cm)	Mean diameter d (cm)
Diameter of the metal bar			

Table 30.2			
	l_1 (cm)	l_2 (cm)	Mean distance l (cm)
Distance between holes containing thermometers T_1 , T_2			

mass of empty beaker $m_1 =$ kg

Table 30.3				
	θ_1 (°C)	θ_2 (°C)	θ_3 (°C)	θ_4 (°C)
After 5 minutes				
After 10 minutes				
After 15 minutes				
At the steady state				

If necessary the time can be extended until the readings of the thermometers reach the steady state.

Mass of the beaker with the water	(m_1)	=
Mass of water	$m_w = m_1 - m_0$	=
Time taken to collect water	t	=

Taking the specific heat capacity of water as $4200 \text{ J kg}^{-1} \text{ K}^{-1}$ calculate k as explained in the theory.

Result

Note down the value obtained from the calculation as the thermal conductivity of the metal.

Discussion

Obtain the standard value of the thermal conductivity of the metal for (copper) from a data book and compare with your experimental value. Calculate the percentage error. Forward your suggestions and ideas to perform the experiment more accurately.

Note

Consider why the side to admit steam to the steam chamber and the side to admit the continuous water steam to the copper tube are being selected this way. (This selection is compulsory). In certain apparatus the lower opening is made larger and the upper opening smaller. In this case the steam can be supplied from the bottom and the chamber would be filled with steam.

Determination of the internal resistance and the electromotive force of a dry cell

Materials and apparatus

A dry cell, a milliammeter, a digital voltmeter, a rheostat (0 - 100 Ω), a tap key, connecting wires and 10 Ω resistor.

Theory

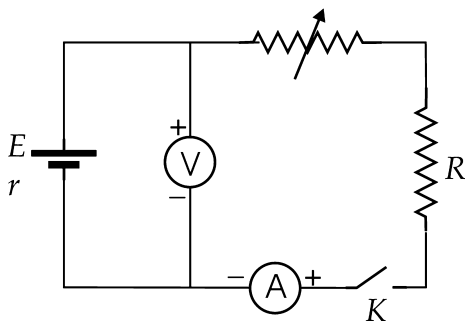

Figure 31.1

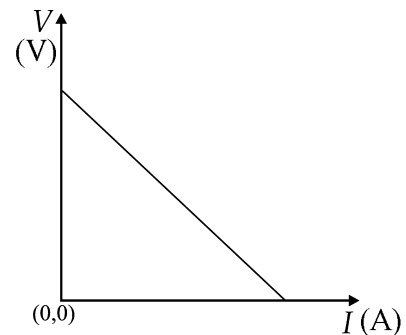

Figure 31.2

In the above circuit if E is the E. M. F. of the cell, r its internal resistance, I the current in the circuit and V the potential difference between the terminals of the cell,

$$E = V + Ir$$

$$V = -Ir + E$$

$$V = -rI + E$$

When V is plotted against I ,

$$\text{Gradient of the graph} = -r$$

$$\text{Intercept} = E$$

Method

Set up the circuit as shown in the Figure 31.1 and adjust the rheostat for its maximum resistance. Observe the reading of the voltmeter with key K open and record the value in the Table 31.1.

Next close the key K, and while decreasing the resistance of the rheostat and varying the value of I by 0.025 A (25 mA) at a time obtain relevant voltmeter readings along with milliampere readings of I (from the milliammeter). Record this readings in the Table 31.1.

Readings and calculations

I (mA)							
V (V)							

Plot V against I . Calculate the gradient and the intercept of the graph. Obtain the initial resistance (r) and the electromotive force (E) of the cell as indicated in the theory.

Results

Conclude the values of the E. M. F. and the internal resistance of the cell as obtained from the results.

Discussion

Discuss the measures taken for the safety of the apparatus and also the courses of action taken to minimize the errors in the experiment.

Note

Due to a large current being drawn for a long time the dry cell would get polarised and be discharged in a little time. The $10\ \Omega$ resistor is used to limit the maximum current. The tap key helps to flow the current for a short period of time. However the tap key has to be pressed sufficiently hard to keep good contact. Since the internal resistance of a digital voltmeter is much higher the current through it can be neglected. Hence it is necessary to use a digital voltmeter for accurate measurement of the potential difference across the cell.

Determination of temperature coefficient of resistance of a metal (Cu) using the Metre Bridge

Materials and apparatus

An insulated copper wire (40 SWG) coil of about 100Ω resistance, a centre zero galvanometer, a sliding contact, two plug keys, a lead accumulator of E. M. F 2 V or two Ni-Cd cells of electro motive force 1.2 V in series, $(0 - 100) ^\circ\text{C}$ thermometer, and a water heater, a wire mesh, a tripod, a bunsen burner, a metre bridge, a $5 \text{ k}\Omega$ resistor, a resistance box $(0 - 500) \Omega$, a rheostat and connecting wires.

Theory

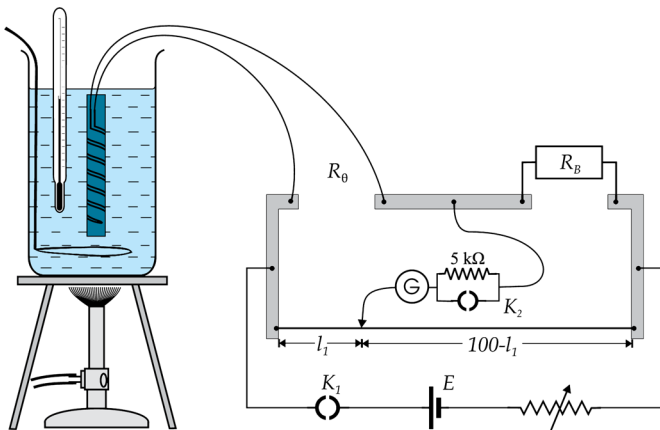

Figure 32.1

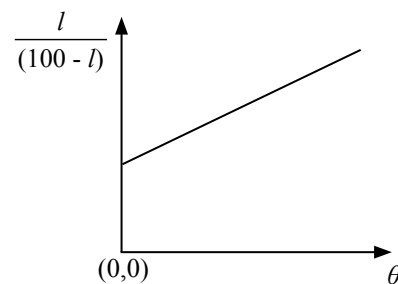

Figure 32.2

As shown in the Figure 32.1, when the bridge is balanced, let R_B be the resistance value of the resistance box, R_θ the resistance of the coil at $\theta ^\circ\text{C}$ and R_0 its resistance at $0 ^\circ\text{C}$, Then,

$$\frac{R_\theta}{R_B} = \frac{l}{100 - l}$$

and $R_\theta = R_0 (1 + \alpha \theta)$, where α is the temperature coefficient of resistance of the metal of the coil

$$R_\theta = R_B \frac{l}{(100 - l)} = R_0 (1 + \alpha \theta), \quad \frac{l}{100 - l} = \left(\frac{R_0 \alpha}{R_B} \right) \theta + \frac{R_0}{R_B}$$

When $\frac{l}{100 - l}$ is plotted against θ , gradient = $\frac{R_0 \alpha}{R_B}$, intercept = $\frac{R_0}{R_B}$

$$\text{Temperature coefficient of resistance } (\alpha) = \frac{\text{Gradient}}{\text{Intercept}}$$

Method

Connect the circuit as shown in the Figure 32.1. Close the switch K_1 and leaving K_2 open, record the initial temperature θ . Stir the water well and obtain the rough balance point. Next close switch K_2 and obtain the accurate balance point. Measure and record the length l . Heat the water while stirring and for every rise of 10°C in temperature obtain relevant balance length l and record in Table 32.1 along with the temperature (θ). Obtain about six pairs of readings.

Readings and calculations

θ ($^\circ\text{C}$)					
l (cm)					
$l / (100 - l)$ (cm)					

Plot $l / (100 - l)$ against θ and obtain the gradient and the intercept of the graph. Calculate the temperature coefficient of resistance (α) as explained in the theory.

Conclusion

Conclude the value you obtained from the experiment as the temperature coefficient of resistance of the metal (copper).

Discussion

Discuss the errors that can occur in the experiment and the courses of action to be taken to avoid these. Obtain the standard value of α from data book and calculate the percentage error of your experimental value and discuss the error.

Note

When preparing the coil of wire take a cylindrical piece of wood about 10 cm in length and diameter about 2.5 cm and an insulated copper wire (40 SWG) of about 5 m in length. Bend the wire into a double thread and wrap it around the piece of wood as shown in Figure 32.3.

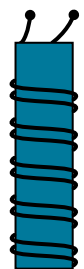

Figure 32.3

Comparison of electromotive forces of two cells using the potentiometer

Materials and apparatus

A potentiometer, a 2 V lead-acid accumulator or two 1.2 V Ni-Cd cells connected in series, a leclanch cell, a daniell cell, a centre zero galvanometer, a two way switch, two plug switches, a 5 k Ω safety resistor, a sliding contact, and connecting wires.

Theory

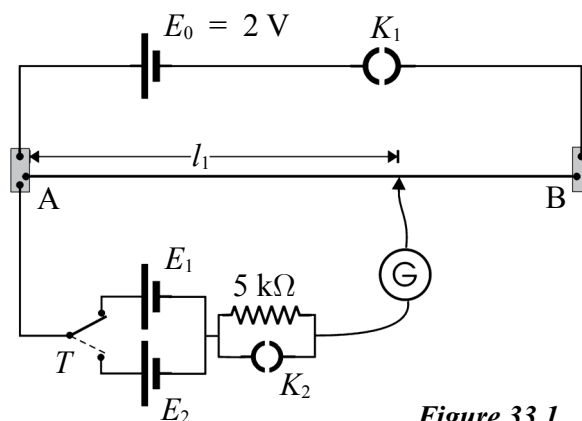

Figure 33.1

If l_1 is the balanced length when the two way switch is connected to the cell E_1 and l_2 is the balanced length when the same switch is connected to the cell E_2 ,

$$\frac{E_1}{E_2} = \frac{l_1}{l_2}$$

Method

Set up the circuit as shown in Figure 33.1. The key K_1 is closed while K_2 is kept open. Connect the two way switch to the cell E_1 . Check the circuit by first touching the end A by the sliding key and observing the direction of the deflection of the galvanometer G, then touching the end B of the wire by the sliding key and observing the direction of the deflection of G again. If the two deflections are in opposite directions confirm the accuracy of the circuit. If not, be concerned about the errors mentioned in the note and correct the circuit. Now find the balance point for the cell E_1 in the usual way by first finding the rough balance point with the key K_2 open and then finding the accurate balance point after closing the key K_2 . Measure the balance length l_1 and record the value.

Repeat the procedure of the cell E_2 by connecting the two way switch to it and obtain the relevant balance length l_2 accurately. Record the value.

Readings and calculations

$$l_1 = \dots\dots\dots \text{ cm}$$

$$l_2 = \dots\dots\dots \text{ cm}$$

$$\frac{E_1}{E_2} = \frac{l_1}{l_2}$$

Substitute the relevant values for l_1 and l_2 and calculate the ratio of E_1 to E_2 .

Results

Conclude the ratio $E_1 : E_2$ as obtained from the calculation.

Discussion

Discuss the precautions you have taken for the safety of the apparatus used in the experiment and also about the errors that would arise and the measures to be taken to minimize these errors.

Note

After setting up the circuit, the key K_1 is closed and the circuit is tested by connecting the two way switch to either cell E_1 or cell E_2 and touching by the sliding switch end A of the wire first and then end B of the wire. If the galvanometer doesn't show deflections in opposite directions on the two occasions the circuit is erroneous. If the galvanometer deflection is in the same direction on both occasions it could be due to one of the following reasons.

- (i) Instead of connecting the positive terminal of cells E_1 and E_2 to the positive terminal of the potentiometer cell E_0 , their opposite negative terminals are connected to it.
- (ii) There could be a loose connection in the potentiometer circuit.
- (iii) The potentiometer cell E_0 is discharged and hence has an electromotive force less than those of E_1 and E_2 .

Also if the galvanometer shows no deflection when the sliding contact (key) touches ends A and B of the wire, test whether there are disconnections in the circuits of E_1 and E_2 and correct the errors.

- The ratio of the electromotive forces of the two cells can be obtained more accurately by a graphical method. For this purpose a resistance box is connected to the potentiometer circuit, and using different resistances from the box corresponding sets of readings of l_1 and l_2 can be obtained. Then,

$$\frac{l_1}{l_2} = \frac{E_1}{E_2}$$
$$l_1 = \left(\frac{E_1}{E_2} \right) l_2$$

By plotting l_1 against l_2 , the ratio E_1 / E_2 can be obtained from the gradient of the graph.

Potentiometers with wires of different lengths are available. These lengths are 2 m, 4 m, 8 m and so on. It is essential to be concerned about the lengths of potentiometer wires when measured by the metre ruler.

Determination of the internal resistance of a cell using the potentiometer

Apparatus

A potentiometer, a 2 V accumulator or two 1.2 V Ni-Cd cells connected in series, a dry cell, a (0 - 50) Ω resistance box, a tap key, a sliding contact (key), a centre zero galvanometer and connecting wires.

Theory

When a cell of emf E and internal resistance r is sending a current through an external resistance R , if V is the potential difference between the terminals of the cell,

$$V = IR$$

$$E = I(R + r)$$

$$V = \left(\frac{E}{R + r} \right) R$$

$$V = \left(\frac{R}{R + r} \right) E$$

If l is the balance length when V is balanced on the potentiometer wire,

$$V = Kl$$

$$\therefore \frac{ER}{R + r} = Kl$$

$$\frac{1}{l} = \left(\frac{Kr}{E} \right) \frac{1}{R} + \frac{K}{E}$$

When $\frac{1}{l}$ is plotted against $\frac{1}{R}$,

$$\text{Gradient} = \frac{Kr}{E}$$

$$\text{Intercept} = \frac{K}{E}$$

$$\therefore r = \frac{\text{Gradient}}{\text{Intercept}}$$

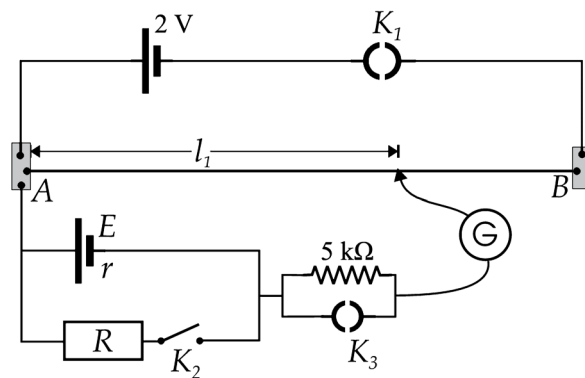

Figure 34.1

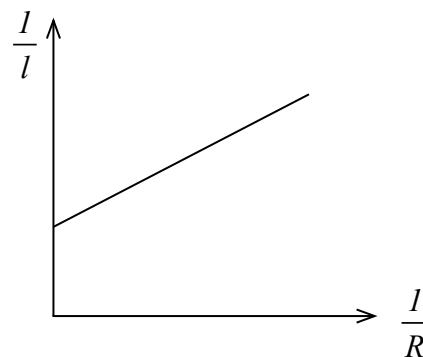

Figure 34.2

Method

Set up the circuit as shown in Figure 34.1. Test the accuracy of the circuit as done in experiment no. 33. Offer a resistance of $R = 50 \Omega$ from the resistance box. Close keys K_1 and K_2 , open K_3 and using the sliding key first determine the rough balance point on the wire. Disconnecting the safety resistor next obtain the accurate balance point. Measure the balance length l relevant to the potential difference V across the cell. Reduce the value R of by 5Ω each time and obtain the relevant balance length l for each value of R . Record all values in the Table 34.1.

Readings and calculations

Table 34.1						
$R (\Omega)$						
$l (\text{cm})$						
$\frac{1}{R} (\Omega^{-1})$						
$\frac{1}{l} (\text{cm}^{-1})$						

Plot $\frac{1}{l}$ against $\frac{1}{R}$.

Gradient of the graph =

Intercept of the graph =

$$r = \frac{\text{Gradient}}{\text{Intercept}}$$

Conclusion

Conclude the value of the internal resistance r as obtained from the calculations.

Note

- Close key K_2 well only when the reading are taken.
- If the minimum value of R is reduced below 20Ω the cell would get discharged in a short period of time.

Construction of the I - V curve for a forward biased semiconductor diode

Materials and apparatus

An 1N 4001 diode, a $5\text{ k}\Omega$ linear potential divider (potentiometer B type), a $100\ \Omega$ 1 W resistor (The first circuit of the semiconductor Diode Trainer available in the school laboratory can be used instead of this set.), a 2 V d. c. power supply, a 0 - 1 V voltmeter (an analogue multimeter of range 2.5 V can be used for this), an analogue multimeter with ranges 2.5 mA and 25 mA (a digital multimeter having ranges $2000\ \mu\text{A}$ - 20 mA is more suitable for this), connecting wires and a bread board / project board.

Theory

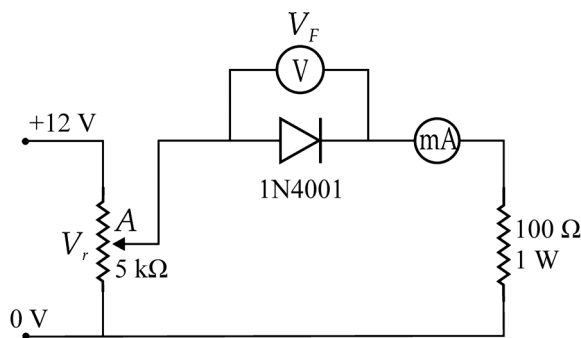

Figure 35.1

When I_F is plotted against V_F , the characteristic curve shown in the Figure 35.2 will be obtained.

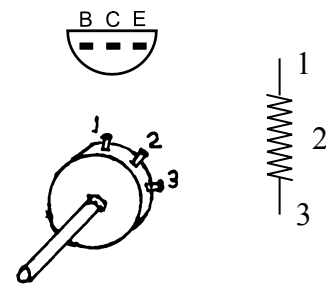

Figure 35.3

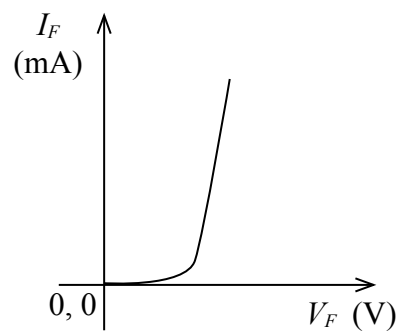

Figure 35.2

Method

Set up the circuit as indicated in the theory (if the circuits of semiconductor diode trainer are used only the ammeter, voltmeter and the cell are needed) supply the current to the circuit by rotating VR anticlockwise until the potential of the terminal A becomes zero. Now starting from 0.1 V reading of voltmeter at terminal A increase the reading by 0.1 V each time (as shown in Table 35.1). Observe corresponding ammeter readings and record all readings in the Table 35.1.

Readings and calculations

V_F	0 V	0.1 V	0.2 V	0.3 V	0.4 V	0.5 V	0.6 V	0.55 V	0.65 V	.675 V	0.7 V	.725 V
I_F μA μA μA μA μA μA μA μA μA μA μA μA

Plot the graph of I_F against V_F .

Extend the linear portion of the graph backwards and determine the voltage (knee voltage) at the point where the graph intersects the V_F axis.

Conclusion

State your conclusion regarding the results.

Discussion

Discuss the ways of obtaining more accurate readings in the experiment.

Note

Since the leakage current of the reverse biased state is in the range of μA it is difficult to measure it. For the 1N 4001 diode when the reverse biased voltage is about 50 V the leakage current is about 10 μA .

For the 5 K Ω linear potential divider, B type potentiometer should be used. The A type resistor which is generally used as the volume controller varies logarithmically and hence when it changes minutely the potential changes highly. Digital type metres should not be used to measure the independent variable since it is difficult to obtain stable values.

Construction of the transfer characteristic curve between I_B and I_C of a transistor in common emitter configuration

Materials and apparatus

A2SD400 silicon transistor, two $5\text{ k}\Omega$ potential dividers [potentiometer (“B” type)], a $10\text{ k}\Omega$ $\frac{1}{4}$ kW resistor, a $100\ \Omega$, $\frac{1}{2}$ W resistor (Instead of all these apparatus the first circuit of the bipolar transistor trainer available in the laboratory can be used.), an analogue multimeter of range 10 V, a $100\ \mu\text{A}$ ammeter or an analogue multimeter of range $50\ \mu\text{A}$, an analogue multimeter of range 25 mA, a 12 V d.c. power supply (or a 6 V accumulator) a circuit board (project / bread board) and connecting wires.

Theory

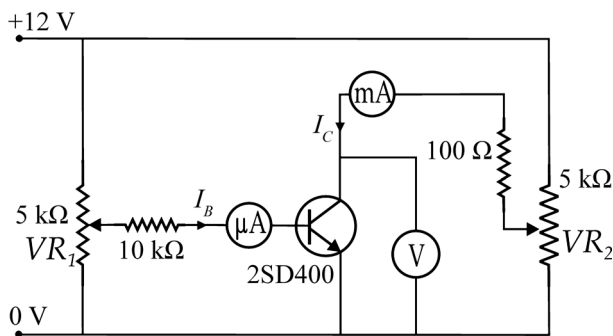

Figure 36.1

When I_C is plotted against I_B a curve as shown in the Figure 39.3 will be obtained. The gradient of the linear portion of the graph will be the direct current gain B of the transistor.

$$\beta = \frac{\Delta I_C}{\Delta I_B}$$

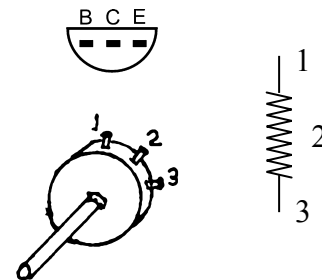

Figure 36.2

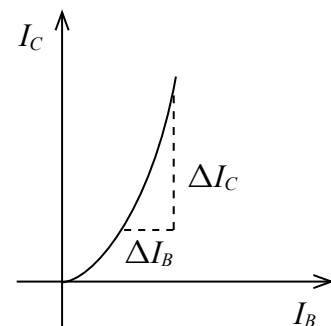

Figure 36.3

Method

Set up the circuit on the circuit board as shown in the Figure 36.1. Rotate both potential dividers VR_1 and VR_2 anticlockwise completely (middle terminal will reach close to the Earth terminal) Now supply the current to the circuit. Rotate VR_2 slowly and clockwise until the voltmeter reading (V_{CE}) becomes 5 V. Since this reading changes when I_B is changed, V_{CE} should be kept constant by VR_2 during the whole experiment. Now rotate VR_1 slowly clockwise, increase the value of I_B starting from 0 by $10\ \mu\text{A}$ each time and obtain values of I_C relevant to the values of I_B . Record all values in the Table 36.1.

Readings and calculations

<i>Table 36.1</i>															
I_B (μA)	0	5	10	15	20	25	30	35	40	50	60	70	80	90	100
I_C (mA)															

Plot I_C against I_B and calculate the gradient of the linear portion.
Calculate β according to the theory.

Conclusion

Conclude the value of the current gain of the transistor.

Discussion

Discuss the behaviour of I_C with I_B and also about the courses of action to be taken for a more successful experiment. Find the value of B of a 2SD400 transistor from a data book and compare it with your answer.

Note

If I_C is to be measured when $I_B = 0$ a micrometer has to be used for the purpose. Even a digital multimeter can be used (instead).

Experimental investigation of the truth tables of simple fundamental logic gates and hence identification of the given gates

Materials and apparatus

Six integrated circuits (TTL IC) 7408, 7432, 7400, 7402, 7486, 74AS836, 3 red LEDs, one blue LED, four $330\ \Omega$, $\frac{1}{4}$ W resistors, a 5 V power supply, a circuit board and connecting wires

Theory

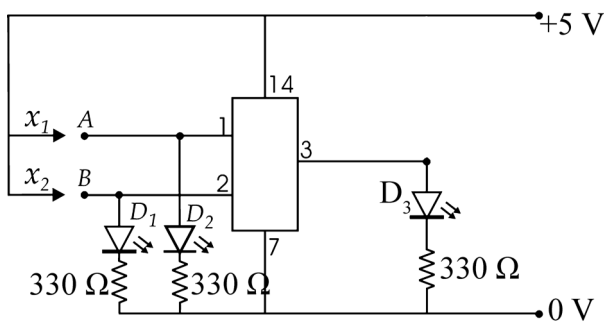

Figure 37.1

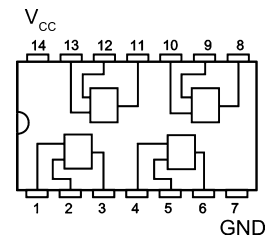

Figure 37.2

When observing the output using LED, D_3 LED not illuminating indicates output 0 V which means logic '0' state and D_3 illuminating indicates output +5 V which means logic '1' state.

Method

Set up the circuit accurately on the project board. Connect the 7th terminal of the integrated circuit to the negative (–) terminal of the 5 V supply and its 14th terminal to the positive (+) terminal of the same supply correctly. Supply the current to the circuit leaving terminals X_1 and X_2 free. Now touch X_1 and X_2 to input terminals A and B giving positive potentials and either lighting up D_1 and D_2 or not, observe the output logic '1' or logic '0' in D_3 . Note down the results in the truth tables. Now remove the integrated circuit from the circuit board. Connect another integrated circuit and repeat in the same manner followed by all other integrated circuits. Enter the result separately in the truth tables for the six ICs.

Readings and calculations

<i>A</i>	<i>B</i>	<i>F</i>
0	0	
0	1	
1	0	
1	1	

<i>A</i>	<i>B</i>	<i>F</i>
0	0	
0	1	
1	0	
1	1	

<i>A</i>	<i>B</i>	<i>F</i>
0	0	
0	1	
1	0	
1	1	

<i>A</i>	<i>B</i>	<i>F</i>
0	0	
0	1	
1	0	
1	1	

<i>A</i>	<i>B</i>	<i>F</i>
0	0	
0	1	
1	0	
1	1	

<i>A</i>	<i>B</i>	<i>F</i>
0	0	
0	1	
1	0	
1	1	

Conclusion

Using the truth table obtained, according to the integrated circuit number, conclude the logic gate in each circuit.

Discussion

Every integrated circuit here includes four equal gates. Only the first gate has been used above. (It is more suitable to keep the input terminals of remaining gates earthed.) Since TTL IC is used here +5 V supply is compulsory. If CMOS IC is used any voltage supply from +3 V to +15 V can be used. Then the values of the control resistors have to be altered. Calculate considering the specifications of LED's as 2.0 V, 10 mA. Instead of the above IC's the CMOS IC's 4001, 4011, 4030, 4071, 4077 and 4081 also can be used without any change of terminals.

eg. : Calculation of the control resistor using a 9 V power supply.

Applying Ohm's law across *R*,

$$(9 - 2.0) = \frac{10 R}{1000}$$

$$R = 700 \Omega$$

The nearest value of the resistor which can be practically bought from the market is 680 Ω and the suitable to select for *R*.

Determination of the Young's modulus of a metal (steel) in the form of a wire

Materials and apparatus

Two uniform steel wires of lengths about 3 m and diameter about 0.5 mm each, both hung from the same rigid support, the main scale (M) calibrated in mm and alongside a vernier scale (V) attached to the other wire, a pan to bear weights, a metre ruler, a micrometer screwgauge and a set of $\frac{1}{2}$ kg weights.

Theory

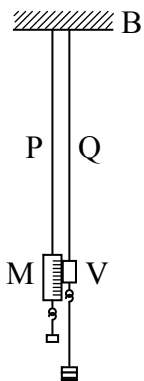

Figure 38.1

If mg is the load suspended, A the area of cross-section of the wire, e the extension of the wire and l the original length of the wire,

$$\text{Young's modulus} = \frac{\text{tensile stress}}{\text{tensile strain}}$$

$$Y = \frac{mg / A}{e / l}$$

$$e = \frac{gl}{AY} \cdot m$$

In the graph e against m ,

$$\text{Gradient} = \frac{gl}{AY}$$

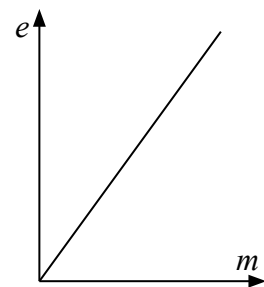

Figure 38.2

Method

As shown in Figure 38.1, hang a dead load from wire P to which the main scale is attached, to keep it free of bends. Hang the pan from the wire Q to which the vernier scale is attached.

Observe the scale reading using the vernier and record it. Now place an initial $\frac{1}{2}$ kg on the pan and obtain the reading on the scale again. Continue adding $\frac{1}{2}$ kg to the load each time and obtain the corresponding scale reading for each total load. After obtaining five/ six readings in this manner remove the added weights in the same order by $\frac{1}{2}$ kg each time and obtain scale readings until the load returns to the initial value. Enter all readings in the Table 38.1.

Measure the length of wire Q from the support up to the vernier using metre ruler and record it.

Also measure using the micrometer screw gauge the diameter of the cross section of the wire Q at three different places, taking two readings normal to each other at every place and record the readings.

Readings and calculations

Table 38.1					
Weight placed on the pan (kg)	Scale reading		Extension		Mean Extension e (mm)
	When adding weights (mm)	When removing weights (mm)	When adding weights (mm)	When removing weights (mm)	
0					
$\frac{1}{2}$					
1					
$1\frac{1}{2}$					
2					
$2\frac{1}{2}$					

Diameter of the wire = (i) mm (ii) mm (iii) mm
 (iv) mm (v) mm (vi) mm

Mean diameter of the wire = mm = m

Area of crosssection of the wire = m²

Length of wire Q (from support to the vernier), l = mm = m

On the same axis, plot separate graphs of e against m from the result obtained while loading and while unloading. Find the gradients of the two graphs. Using the mean of the two gradients, calculate the Young's modulus of the metal of the wire as explained in the theory.

Gradient of the graph e against m = m kg⁻¹

(Taking $g = 10 \text{ m s}^{-2}$ and converting the area of crosssection A into m², calculate Y by using the expression for the gradient.)

Conclusion

Conclude the value you obtained from the results as the Young's modulus of the material of the wire.

Discussion

Obtain the standard value of Y from a data book, compare with the value you obtained from the experiment, find the error and then the percentage error.

Note

- Since both wires are from a single wire of the same material and are hung from the same rigid support, any errors due to yielding from the support and changes of temperature are minimized.
- By removing the weights and taking readings it can be ascertained whether the elastic limit is exceeded or not.
- During loading any bends and kinks in the wire can get straightened and observed as extensions. Such errors get identified during unloading and hence can be corrected.
- Discuss the precautions you would take to minimize the errors.

Determination of the coefficient of viscosity of a liquid (water) by capillary flow method using Poiseuill's formula

Materials and apparatus

A capillary tube of about 25 cm length, a constant pressure apparatus, a measuring cylinder (100 ml), a meter ruler, a stand, a stop clock, a travelling microscope, a cotton thread, small quantities of solutions of nitric acid and sodium hydroxide, connecting rubber tubes and a spirit level,

Theory

If V is the volume of a liquid flowing in a time t under a pressure p through a capillary tube of length l and radius r , then according to Poiseuill's formula,

$$\frac{V}{t} = \frac{p \pi r^4}{8 \eta l}$$

If the height between liquid levels is h , the density of the liquid is ρ and the acceleration due to gravity is g ,

$$p = h \rho g$$

$$\text{Hence } \frac{V}{t} = \frac{h \rho g \pi r^4}{8 \eta l}$$

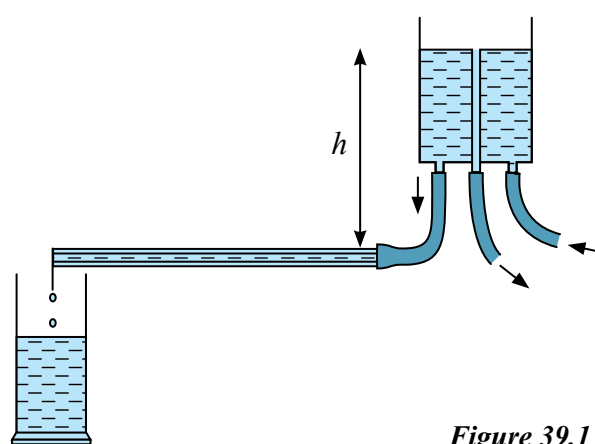

Figure 39.1

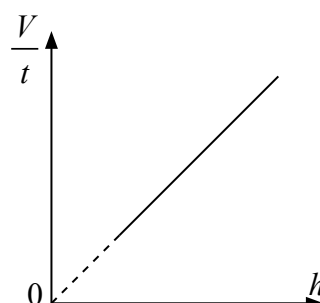

Figure 39.2

Method

Wash the capillary tube first sodium hydroxide solution, secondly with diluted hydrochloride solution and finally with well water. As shown in the Figure 39.1 connect the capillary tube to the constant pressure apparatus by means of a rubber tube and fix the tube on the stand while levelling it using the spirit level. Attach a piece of the cotton thread near the open end of the tube, open the tap and adjust the constant pressure apparatus to obtain a slow trickle of water from the tube. Place the measuring cylinder under the open end of the tube while starting the stop clock at the same time. Collect the water for a specific period of about 3 minutes until a sufficient quantity of liquid (water) collects in the cylinder and note down the volume collected and the time elapsed. Using the metre ruler measure the height of the liquid pressure head (h). Obtain more readings for different values of h by varying the pressure head and record all the recordings in the Table 39.1. Measure the length of the capillary tube by the metre ruler. Using the travelling microscope measure the internal diameter of the tube in two directions normal to each other.

Readings and calculations

Table 39.1		
h (cm)	V (cm ³)	V/t (m ³ s ⁻¹)

Time of flow of liquid (water)	(t)	= s
Total length of capillary tube	(l)	= cm
Diameter of capillary tube	(d_1)	= cm
Diameter in the normal direction	(d_2)	= cm
Mean diameter	$\left(\frac{d_1 + d_2}{2}\right)$	= cm
Mean radius of the capillary tube	(r)	= cm

Calculate the coefficient of viscosity of the liquid (water) using the expression in the theory.

Conclusion

Conclude the value you obtained in the calculation as the coefficient of the viscosity of water.

Discussion

Compare the standard value of the coefficient of the viscosity of water with your experimental value and calculate its percentage error.

Note

A more accurate value for the internal radius of the tube can be obtained by inserting a thread of mercury into it, measuring its length by the travelling microscope, then measuring the mass of the mercury thread using the triple beam balance and calculating the radius using the relevant formulae.

- Since r^4 appears in the expression and r being a decimal number, r becomes the value to be measured most accurately.
- For high values of h , if the graph of V/t against h becomes a curve. it can be concluded that this may be due to the velocity of the flow of the liquid exceeding the critical velocity. Hence the straight line portion of the graph should be used to find the gradient.
- The object of hanging a cotton thread at the end of the capillary tube is to prevent the water flowing away and also forming a water layer due to surface tension creating a pressure difference.

Determination of the surface tension of water using a microscope slide

Materials and apparatus

A microscope slide, a petri dish, a four beam balance, a vernier calliper, few pieces of wire, a diluted sodium hydroxide solution, and a diluted nitric acid solution, a micrometer screwgauge

Theory

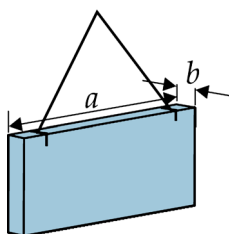

Figure 40.1

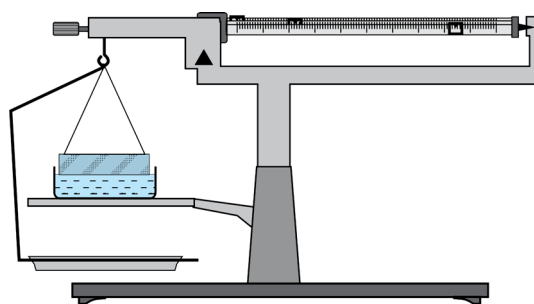

Figure 40.2

Let mg be the load that balances the surface tension force on the lower perimeter of the slide just touching the water surface when the slide is suspended from the balance. Also let T be the surface tension of water and a and b the length and thickness respectively of the slide.

$$\text{Then, } 2(a + b)T = mg$$

Method

Wash the microscope slide first with the diluted hydroxide solution, next with the diluted nitric acid solution and finally well with water and clean it. Then suspend it horizontally by means of clips and strings from the balance and adjust the balance for equilibrium. Raise the water beaker slowly and allow the lower surface of the slide to just touch the water surface in the beaker as shown in Figure 40.2. The equilibrium of the balance will now be disturbed. Restore equilibrium again and find the extra load that was needed for it. Remove the slide and find its length by the vernier calliper and thickness by the micrometer screwgauge in three places.

Readings and calculations

Thickness (mean) of the slide	b	=	cm
Length (mean) of the slide	a	=	cm
Excess load used		=	g

Calculate the surface tension of water (T) using the theory.

Conclusion

Conclude the value of the surface tension of water as obtained from the calculation.

Discussion

Discuss your results by comparing with the standard value of the surface tension of water.

Note

- Since the surface tension of water varies with temperature, it is more suitable to note down the temperature during the experiment and decide according to the temperature.
- It has been assumed that water wets glass and hence the angle of contact is zero.
- Care should be taken to use the situation that the slide just touches the water surface. If not an upthrust would exist and has to be accounted for.
- For the final washing of the slide tap water and not distilled water should be used. Since substances such as grease is used in the production of distilled water it could contain oily dirt.

Determination of the surface tension of water by capillary rise method

Materials and apparatus

A capillary tube of about 15 cm in length, a travelling microscope, a beaker, an adjustable bench, a pin or a pointer bent at a right angle, pure water, diluted sodium hydroxide and diluted nitric acid solutions in small amounts, a stand and thin rubber loops.

Theory

If h is the capillary rise of a liquid of surface tension T , and density ρ in a capillary tube of radius r ,

$$\text{then} \quad \frac{2 T \cos \theta}{r} = h \rho g$$

where θ is the relevant angle of contact.

The angle of contact between pure water and clean glass is considered to be zero.

$$\text{Then,} \quad \frac{2 T}{r} = h \rho g$$

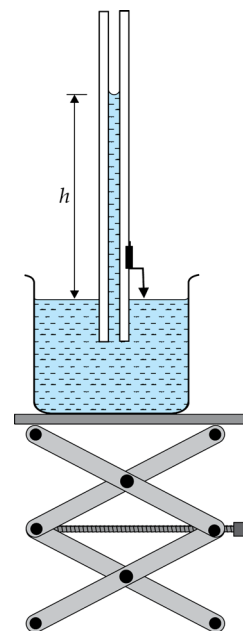

Figure 41.1

Method

Wash the capillary tube first with the diluted sodium hydroxide solution, then with the diluted nitric acid solution and finally with pure water and dry it. Place the beaker of water on the adjustable bench, attach the bent pin or pointer to the capillary tube by means of rubber loops and fix the tube vertically to the stand so that the lower end of the tube just gets immersed in the water in the beaker as shown in Figure 41.1.

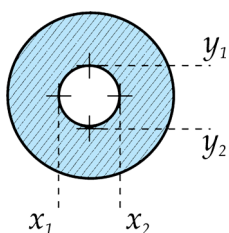

Figure 41.2

Then by lowering or raising the adjustable bench or otherwise get the tip of the pin to just touch the water surface after the capillary rise of the liquid in the tube is complete. Observe the water meniscus in the tube through the travelling microscope. Focus the image (which will be inverted) so that the base of the meniscus touches the horizontal crosswire of the microscope. Obtain the reading (h_1) on the vertical scale of the microscope. Next remove the beaker of water, lower the microscope along its vertical scale and focus it to the tip of the pin (or pointer) with its image touching the horizontal cross wire of the microscope. Obtain the reading (h_2) on the vertical scale of the microscope. In order to find the internal diameter of the capillary tube, adjust the cross-wires of the travelling microscope coinciding as shown in Figure 41.2 below and obtain readings (x_1, x_2 and y_1, y_2) for two diameters perpendicular to each other and record the values.

Readings and calculations

$h_1 =$	$h_2 =$
$x_1 =$	$x_2 =$
$y_1 =$	$y_2 =$
Capillary rise ($h_1 - h_2$) =

Mean diameter of the capillary tube $d = \left[\frac{(x_2 - x_1) + (y_2 - y_1)}{2} \right]$

Radius of the capillary tube $r = \frac{d}{2} =$

Calculate the value of the surface tension T of water using the theory.

Conclusion

Conclude the value you obtained in the calculation as the surface tension of water.

Discussion

Discuss any suggestions to increase the accuracy of the results.

Note

The capillary rise can be obtained at a few more places along the tube by changing the amount the tube is immersed in the liquid and calculate the surface tension. By taking the mean of all these values of surface tension any error due to non-uniformity of the capillary can be minimized.

Determination of the surface tension of a liquid by Jaeger's method

Materials and apparatus

Jaeger's apparatus set, a beaker, the liquid of which surface tension is required, a quantity of kerosene oil, a travelling microscope, a block of wood or an adjustable bench and two stands

Theory

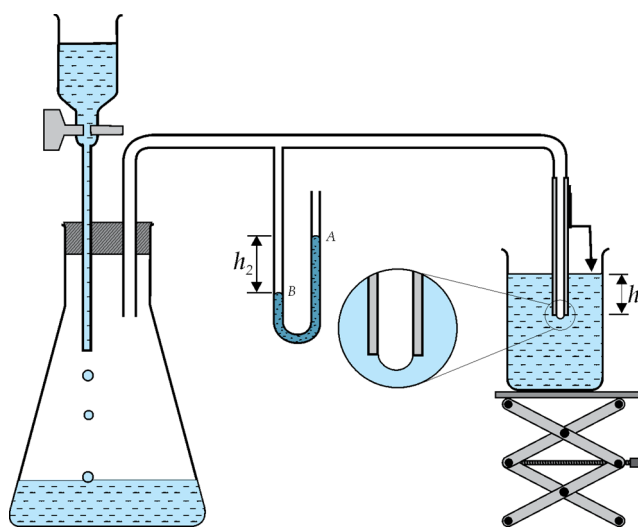

Figure 42.1

Let T be the surface tension of the liquid, ρ_1 its density, ρ_2 the density of kerosene oil used in the manometer, r the radius of the capillary tube in the apparatus, h_2 the maximum height between the liquid levels in the manometer, h_1 the depth of the lower end of the capillary tube from the liquid level in the beaker and p_0 the atmospheric pressure. Then,

$$\text{Pressure inside the bubble} \quad (p_1) \quad = \quad p_0 + h_2 \rho_2 g$$

$$\text{Pressure outside the bubble} \quad (p_2) \quad = \quad p_0 + h_1 \rho_1 g$$

$$\text{Excess pressure in the bubble} \quad = \quad p_1 - p_2$$

$$= (h_2 \rho_2 - h_1 \rho_1) g = \frac{2T}{r}$$

Method

Set up the Jaeger's apparatus as shown in the Figure 42.1. Introduce a sufficient amount of kerosene oil into the manometer. Fix the capillary tube vertically on a stand. Place the beaker containing the liquid on the adjustable bench or any other suitable stand and adjust it so that the lower end of the

capillary tube gets immersed in the liquid as shown in Figure 42.1. Attach a bent pin or a pointer to the capillary tube so that its tip touches the liquid level in the beaker. Now open the tap T_1 so that water will flow orderly into the larger flask. Obtain the situation that the increasing pressure in the flask would force air out of the capillary tube end into the liquid in the beaker in the form of an air bubble.

In order to find the maximum height difference in the manometer, first observe the highest position of the liquid level in limb A of the manometer and focussing the travelling microscope to the lowest position of the meniscus in the position record the reading h_1 on the vertical scale of the microscope. Next observe the lowest position of the meniscus in the limb B and after focussing the microscope to the position of the meniscus observe and record the reading (h_2) on the vertical scale. Enter the readings in the Table 42.1 given below.

Now remove the liquid beaker, observe the tip of the pin or pointer attached to the capillary tube through the microscope, focus the tip on the horizontal cross wire of the microscope and obtain the reading h_3 on the vertical scale. of the microscope (Figure 42.2). Similarly focus the microscope to the lower end of the capillary tube and obtain the reading h_4 on the vertical scale. Record these readings too in the Table 41.2.

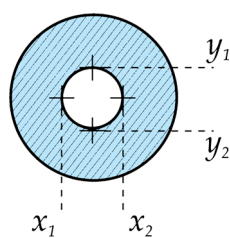

Figure 42.2

Readings and calculations

Table 42.1							
h_1	h_2	h_3	h_4	y_1	y_2	x_1	x_2

$$h_1 = h_3 - h_4$$

$$h_2 = h_1 - h_2$$

$$\text{Diameter of the capillary tube} = \left[\frac{(y_2 - y_1) + (x_2 - x_1)}{2} \right]$$

Substituting the values of r_1 and r_2 , h_1 and h_2 and the radius $r (= d/2)$ in the expression given in the theory calculate the value of the surface tension T .

Conclusion

Conclude the value of T you obtained from the calculation as the surface tension of the liquid.

Note

When the radius of the bubble in the liquid increases, reduce the rate of fall of water drops from the funnel by adjusting the tap T_1 . Observe the instance of the maximum difference of levels several times from the manometer when the bubble gets released and obtain the readings h_1 and h_2 at the best chosen instance. By heating the liquid in the beaker and taking readings at several temperatures while maintaining each temperature constant, the value of surface tension can be found at different temperatures. The variation of surface tension with temperature can then be studied.

References

දහනායක, සී. (2003). ප්‍රායෝගික භෞතික විද්‍යාව, ස්ටැම්ෆර්ඩ්ලේක්, පන්තිපිටිය.

Breithaupt, J. (2003) Understanding Physics For Advanced Level - Fourth Edition.
Nelson Throne, Cheltenham, UK.

Edmonds Jr., D. S. (1993). Cioffari's Experiments in College Physics - Ninth Edition. D. C.
Heath and Company, Massachusetts, USA.

Muncaster, R. (1993). A-level Physics - Fourth Edition. Stanley Thornes (Publishers) Ltd,
Cheltenham, UK.

Nelkon, M. & Ogborn, J. M. (1987). Advanced Level Practical Physics - Fourth Edition.
Heinemann Educational Books, London, UK.

Tyler, F. (1961). A Laboratory Manual of Physics - Second Edition. Edward Arnold Publishers
Limited, London, UK.

Mather, U. B. (1951). Experiments in Physics for First Year Students - First Edition. Ceylon
University Press, Colombo.

Smith ,C. J. (1947), Intermediate Physics. Edward Arnold Publishers Limited, Lincoln, UK.